

PCI / PCIE / LPC/MiniPCI-E/EC Desktop Laptop Computers Diagnostic Card User Manual ver:6.0

Contents will be updated when available without further notice

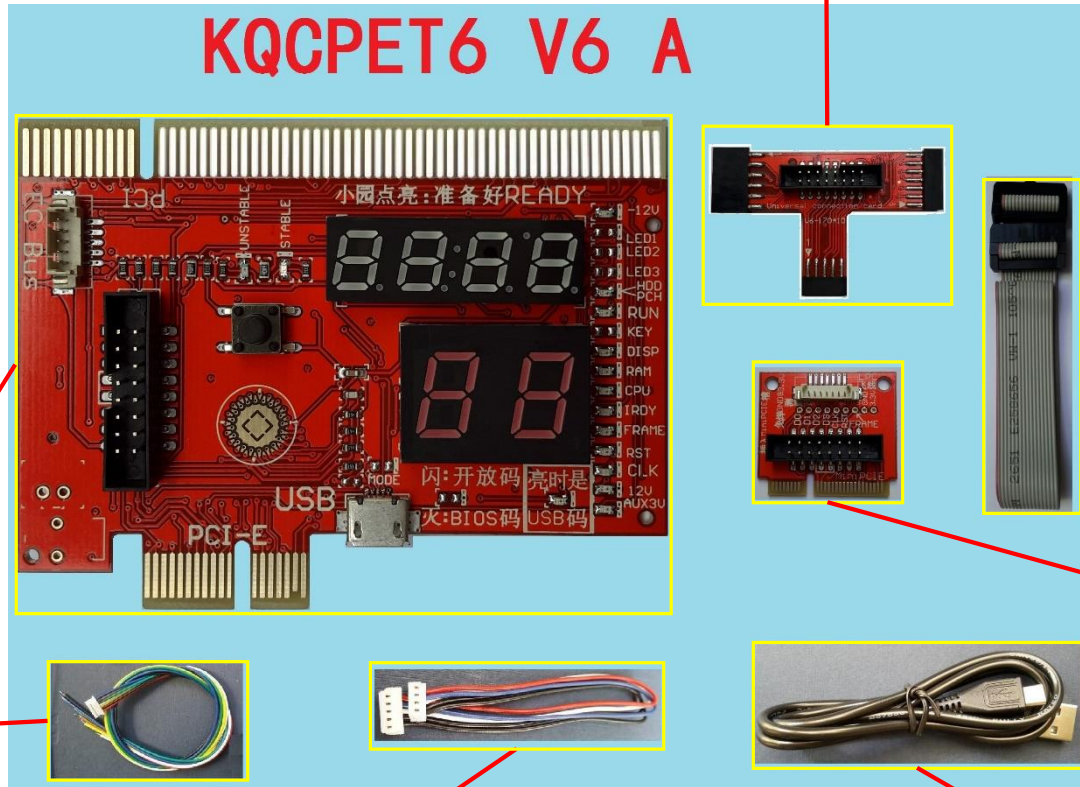

KQCPET6 V6 TypeA Master Diagnostic Board and Accessories



T-Card (works on Desktop PC LPCs)

Supports PCI / PCI-E / LPC / MiniPCI-E / EC bus

Extension Cable (Connects the T-Card and miniPCIe Adapter to the Master Diagnostic Board

MiniPCI-E adapter

LPC wire

EC wire

USB cable (72cm) only need to be used when using the LPC or miniPCIe diagnosis. This cable needs to be connected before powering on the computer to run the diagnosis.

Simple Error LED Light Indicators

- New simple faults LED lights, show the computer faulty areas, no need to use any digital codes interpretation, much easier than the LCD screen diagnostic cards.
- Tech fact: Due to the periodical updates of the newer bios codes from the Bios and/or the computers manufacturers, only the Bios and/or the computer manufacturers have the most updated and complete lists of the Bios codes. These LED lights work just as same as those on all other diagnostic cards on the market and need to rely on the updated Bios codes, please use these LED codes as a quick reference.

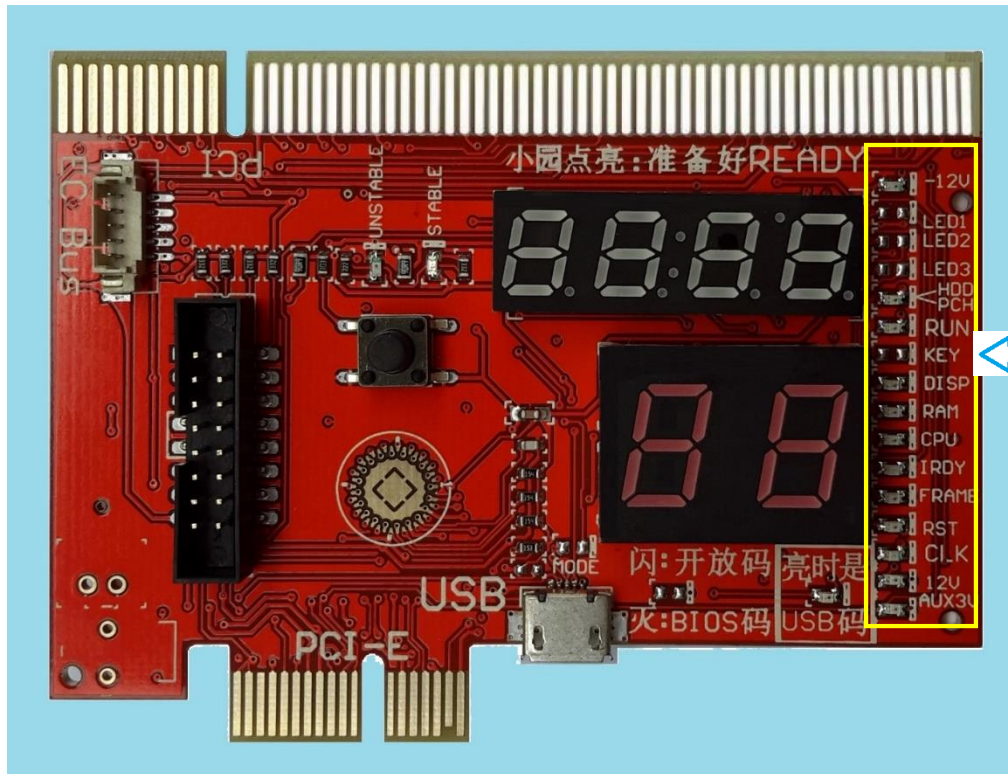

-12V	←	Main power/motherboard
HDD/PCH	←	Bridges/HDD/USB/SATA
RUN	←	CPU working status
DISP	←	video card
RAM	←	Ram memory
CPU	←	CPU
IRDY	←	PCI slot detected mobo
FRAME	←	Motherboard signal
RST	←	Motherboard reset
CLK	←	Motherboard clock signal
12V	←	Motherboard signal
AUX3V	←	PSU/motherboard power

LED lights corresponding parts check diagram

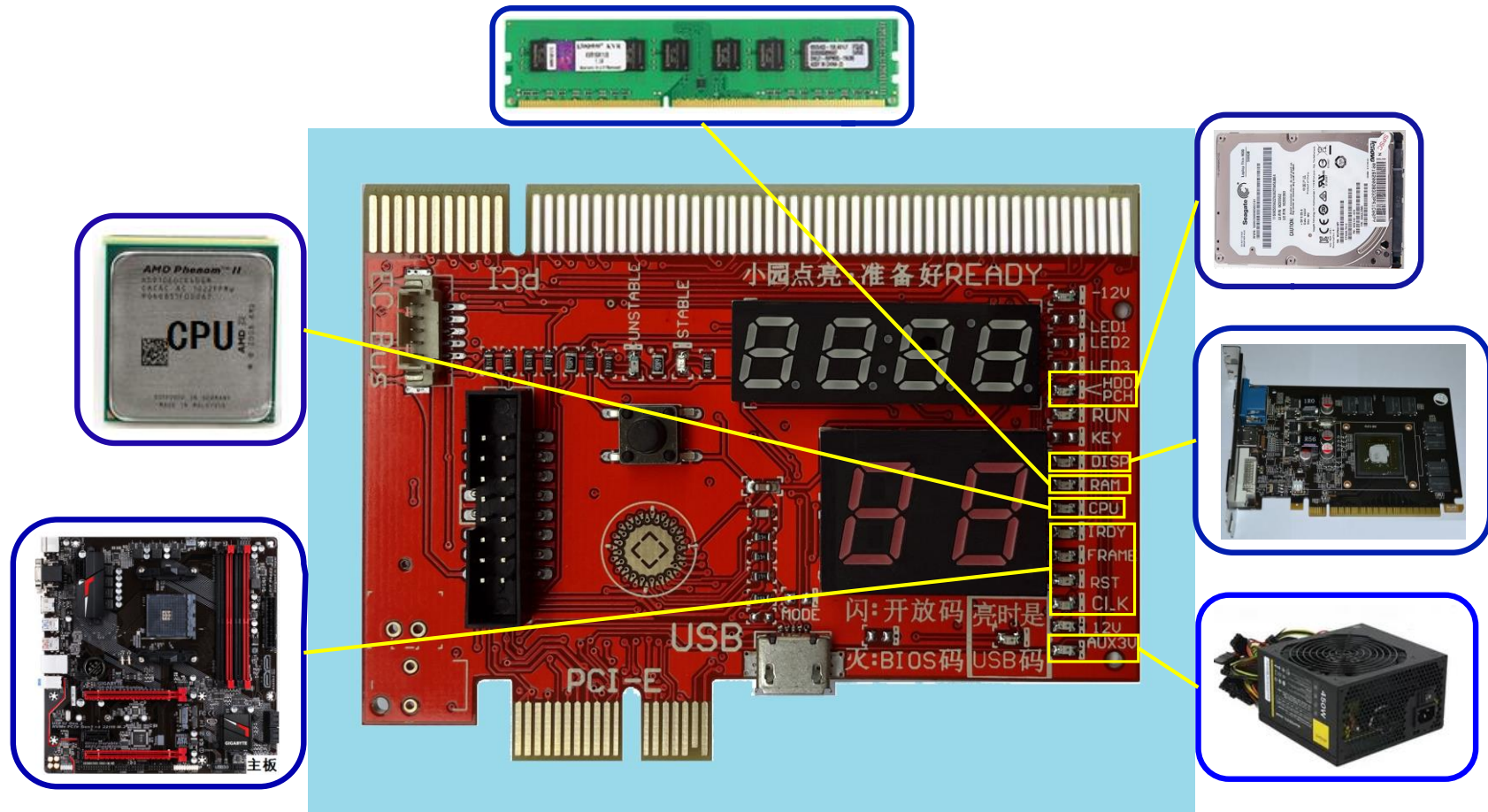

KQCPET6 V6 all available LEDs

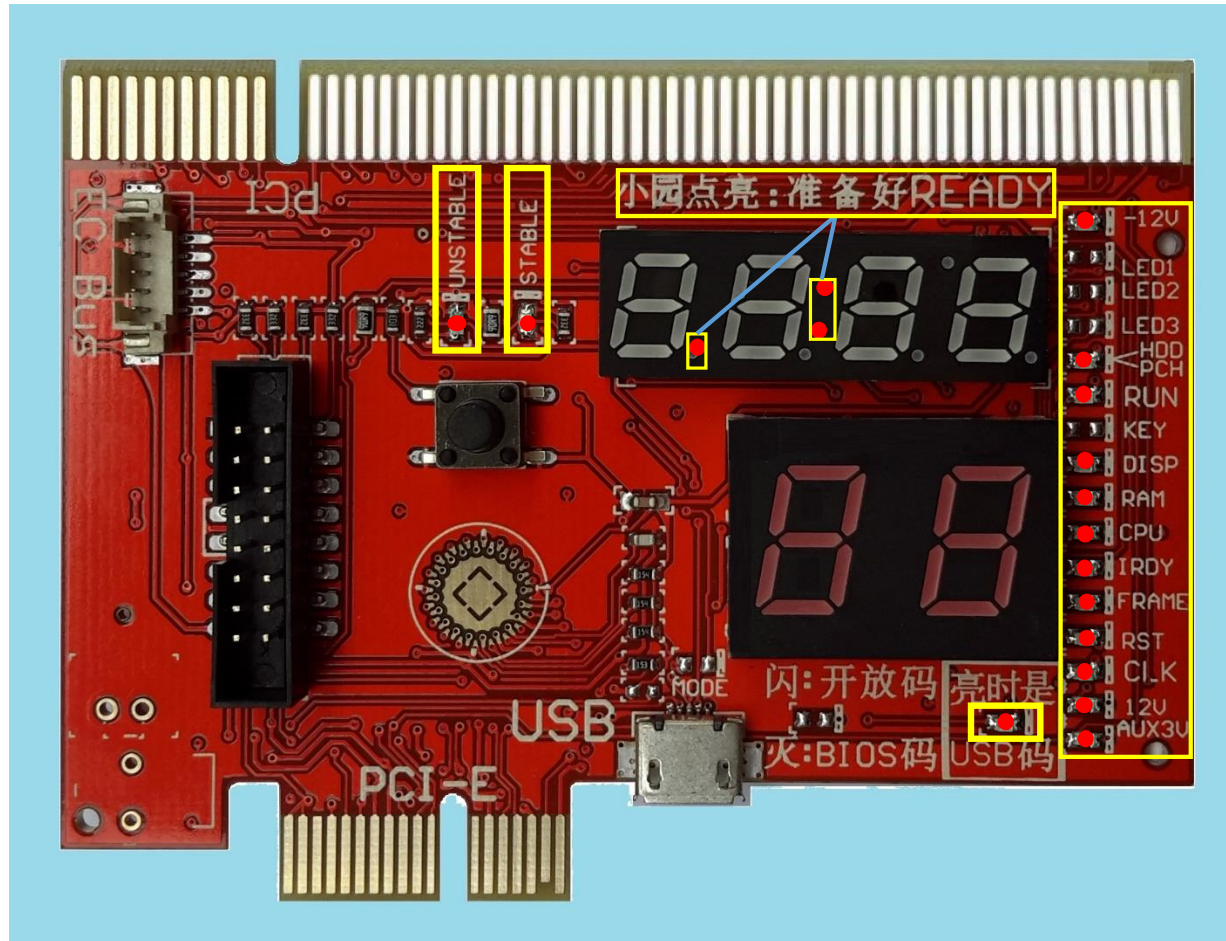

KQCPET6 V6 LED Light Descriptions

Indicator Light	Signal	Illustration
Unstable	Not stable	If the computer motherboard is not stable, with potential faults or computer accessories parts are not fully compatible with the motherboard, this LED will be steady ON. (Only PCI and PCIe diagnosis comes with the Stability Test feature)
Stable	stable	The computer is stable, no error. (Only PCI and PCIe diagnosis comes with the Stability Test feature)
Ready	Computer ready	When this LED light ON(please take note all 3 dots must light up on the 4digital display, please check above picture), ok to reboot computer to do the stability test. If these Ready LED is not On, do not reboot computer for the Stability Test. (Only PCI、PCIE connections come with Stability Test feature)
-12V	Power	When the test card installing on the standard PCI slot , this LED will be steady ON otherwise, there is no such voltage from PSU or the motherboard is short. When using LPC、PCIE、MINIPCIE、EC、USB connections to test the computer, this LED need not to be On.
HDD/PCH	HDD / Bridges	Hard Drive / Bridges (North or South) / SATA / USB modules self test failed
RUN	CPU RUN status	Shows the CPU been running, as soon as CPU been initialized and run, this LED will light, even though the CPU stopped working now, this LED will remain ON. To check on this LED, remove the CPU, power on the motherboard, if this LED still remains ON, the LED need to be checked for fault.
DISP	Video card / mobo GPU	Video card / integrated motherboard GPU self test failed
RAM	Memory / mobo RAM	RAM / motherboard memory module or power fault
CPU	CPU	CPU / motherboard CPU coprocessor module or peripheral path self test failed
IRDY	Major device is ready	Improved IRDY LED light, unique LED light when using the PCI slot, this LED lights ON when there is IRDY signal, works the same way as the CLK signal . This LED is absent when using the LPC、PCIE、MINIPCIE、EC connections.
FRAME	Frame period	Improved FRAME LED light, it lights ON when there is frame cycle signals, works the same way as the CLK LED.
RST	Reset	This LED flashes very quickly for about half a second when using the test card on the PCI slot during the power ON or pressing the Reset button on the computer. It remains ON if the reset wire connects to the wrong other pins on the motherboard or the motherboard reset circuitry is faulty. When using the LPC connection to test the computer, this LED may not light at all, please focus on the digital diagnostic codes. Only connecting with PCI or PCIe, this LED shows the motherboard reset activity.
CLK	Main Bus Clock	This LED lights when there is CLK clock pulse signal. This LED may flash fast enough so that it looks like never light at all.
12V	Power	This LED should remain steady ON when the test card is installed on the computer PCI slot , otherwise, there is no such voltage from the PSU or the motherboard is shorted. When using the LPC、PCIE、MINIPCIE connections, this 12v LED should remain OFF.
AUX3V	Power	This LED is the unique 3.3v indicator on PCI、PCIE slots, should remain ON when the motherboard is powered ON. A few motherboards with built in PCI slots may not have this voltage. LPC connection does not have this voltage, so this LED will remain OFF.
Open codes	Open Code indicator	Except code 'no', when this LED flash ON and OFF, the codes are the 2digit Qiguan open codes. If this LED remains OFF, the codes are Bios Code. On TypeB cards, this LED steady ON indicates the USB codes.

PCI/PCIE/LPC/MiniPCI-E/EC Diagnostic Card (TypeA frontview)

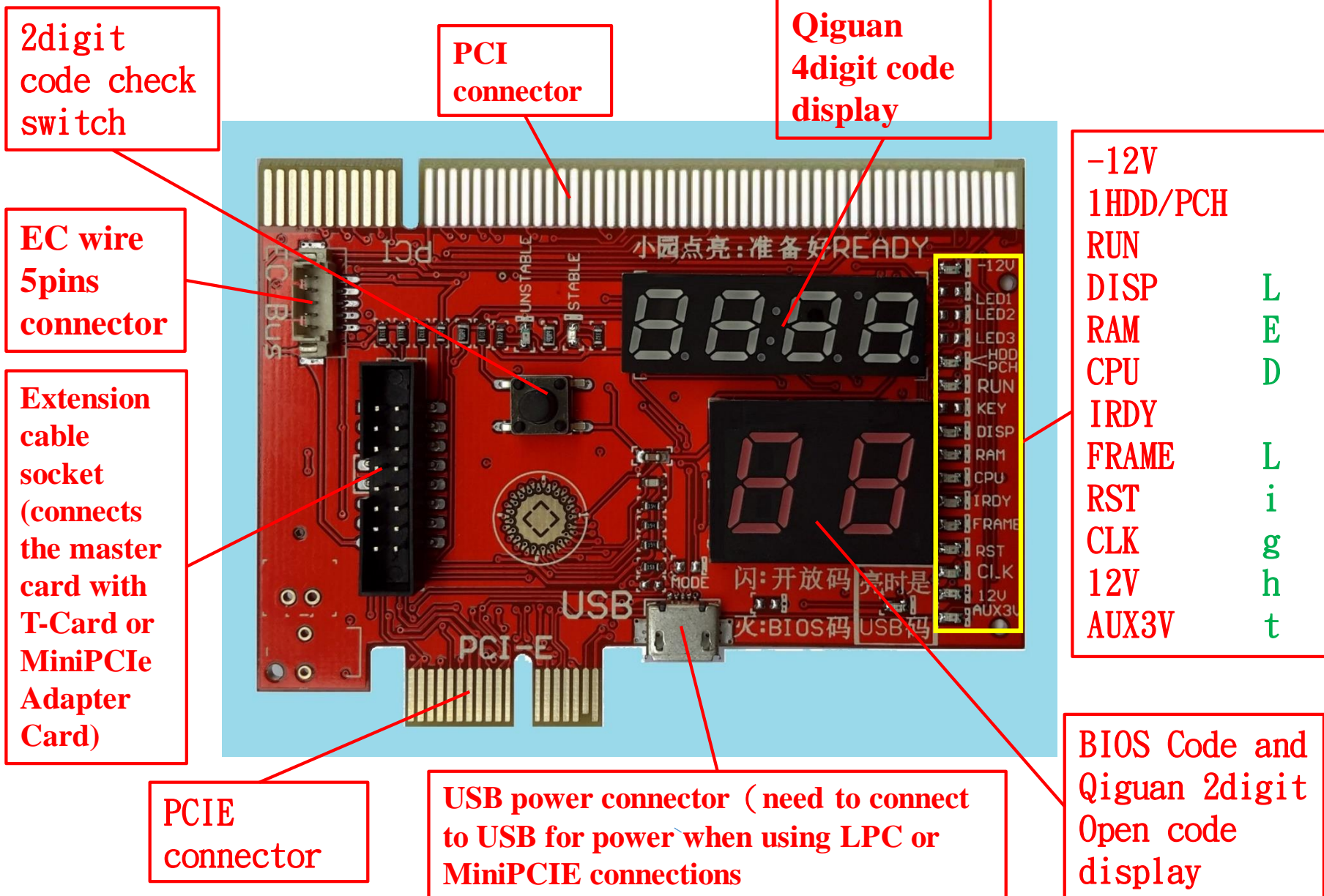

PCI/PCIE/LPC/MiniPCI-E/EC Diagnostic Card (Master Card back side)

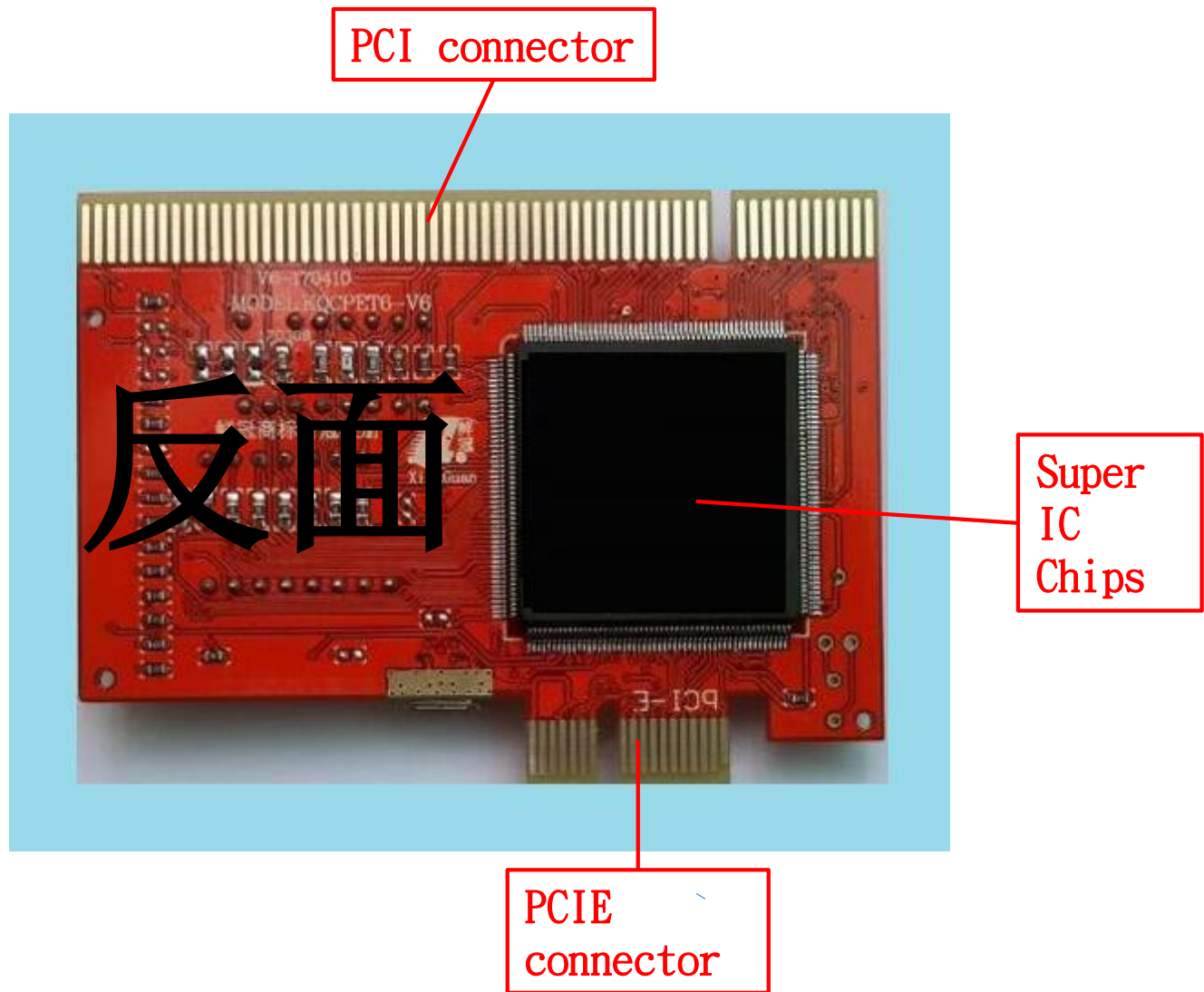

Precaution for the Diagnostic Card PCI/PCI-E 1X Connection

- When there is PCI and PCIe connectors on the same motherboard, please use the PCI slot.
- When there is only PCI-E slot, please install the diagnostic card PCIe connector to the motherboard PCI-E X1/X4/X8/X16 connector.
- Important : Never connect the diagnostic card PCIe connector to the motherboard non PCIe connectors (PCI or AGP slots...etc), this may short the diagnostic card and/or motherboard when the power is ON.

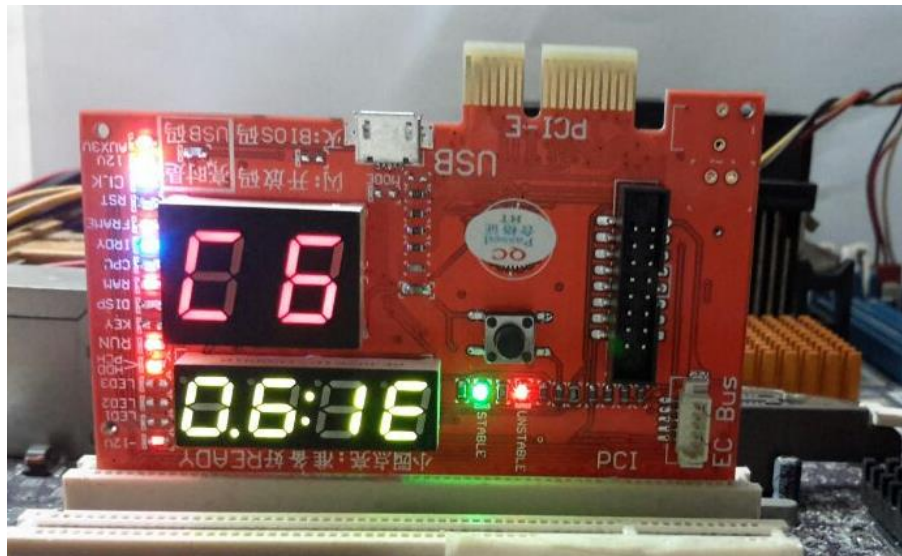

Correct

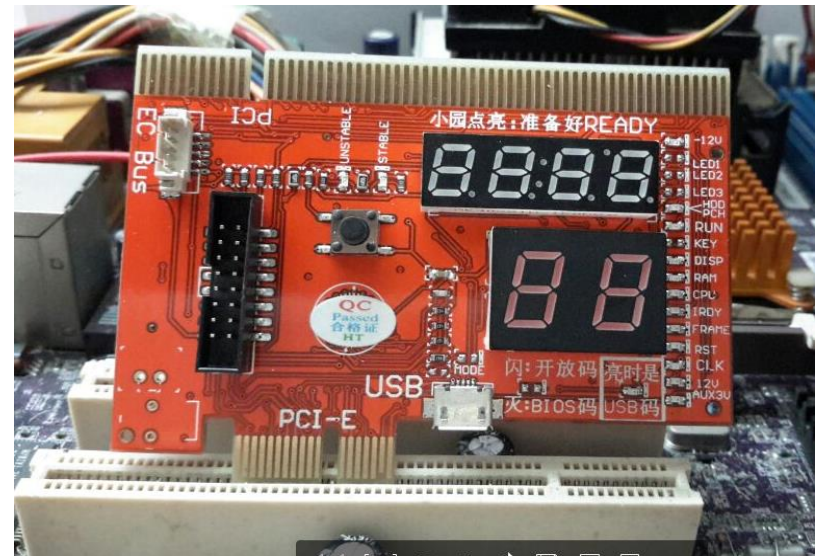

Wrong

Diagnostic Card and Motherboard PCI-Express x1

- When there are different PCIe connectors available on the motherboard, please install the diagnostic card on the PCI-Express x1、x4、x8、x16 slots, (please pay attention that some motherboards only x1 slot get the diagnostic codes.)

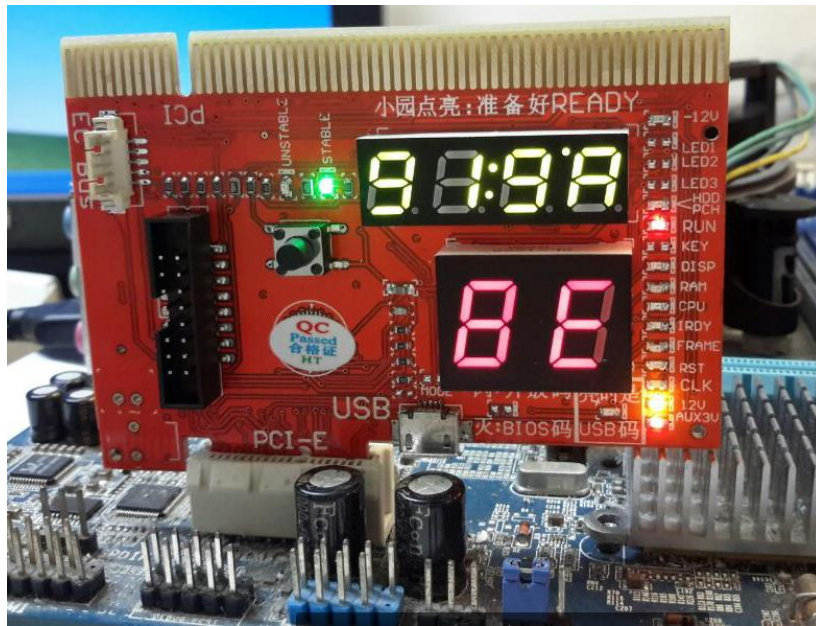

Correct

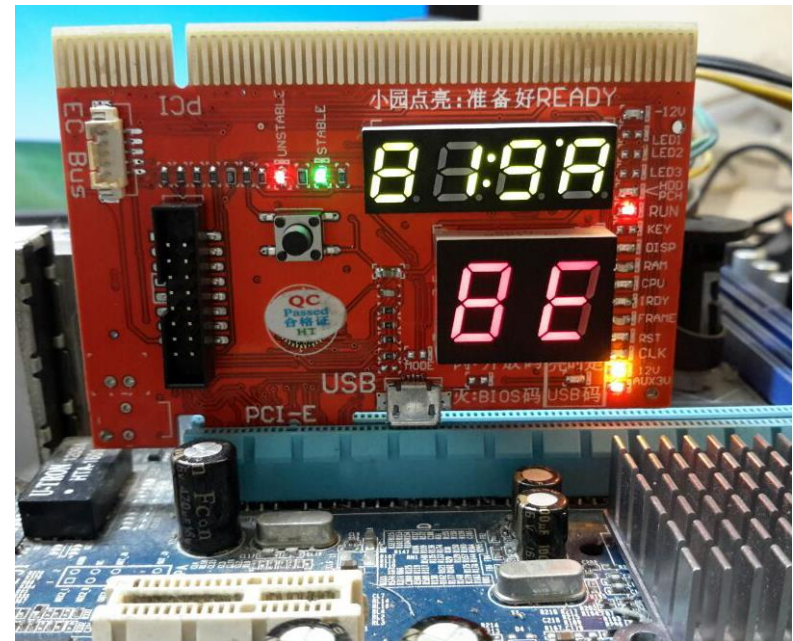

Correct

Diagnostic Card and Motherboard PCI-E X4/X8/X16

- When using the motherboard PCI-E connections, we may use the PCI-Express x4/x8/x16 slots, please pay attention that some motherboard only PCI-E x1 slot provides the diagnostic codes. The following picture show the correction installation of the diagnostic card on the PCI-E X4/X8/X16 connectors.

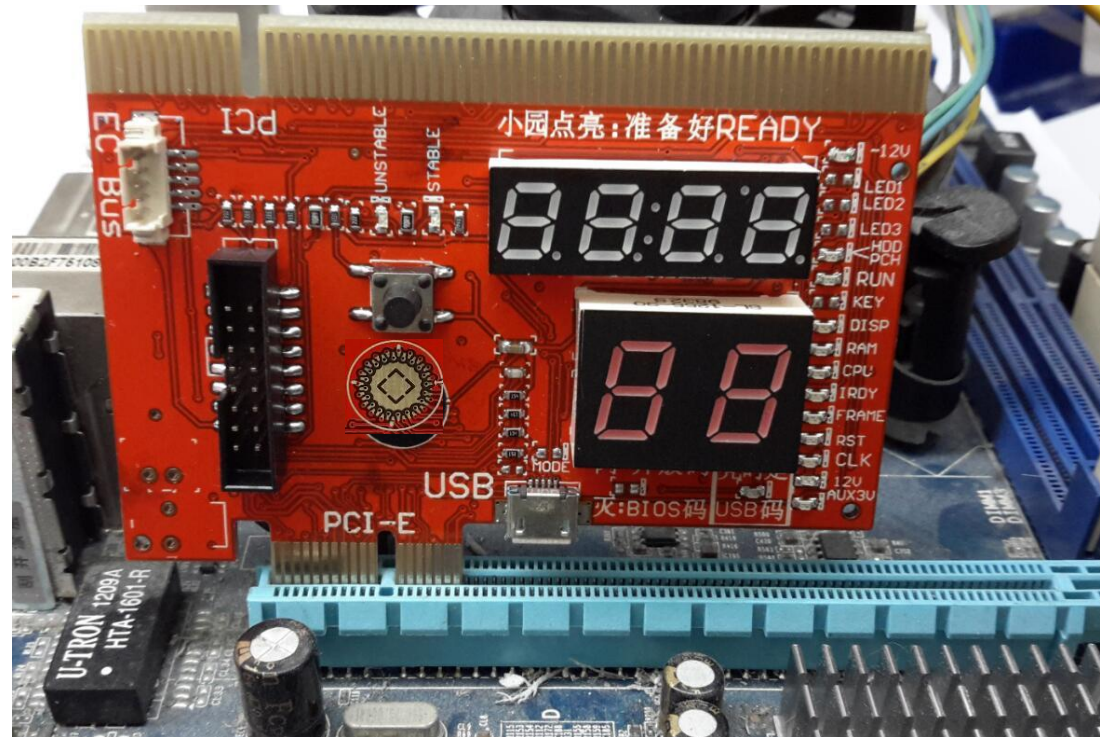

The correct installation of the diagnostic card on the PCI-E X16 connector

The Wrong Installations of the Diagnostic Card to the Motherboard PCI-E x4/x8/x16 Connectors

- When using the PC motherboard PCI-Express x4 · x8 · x16 connections, please watch not to install the diagnostic card incorrectly. Installing the diagnostic card wrong to the PCIe connectors will cause the shorts when powering ON. The following pictures show the wrong installations.

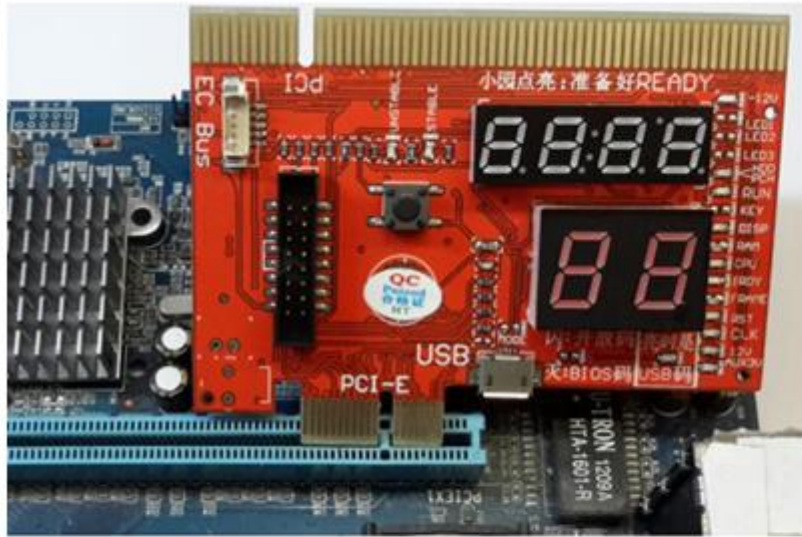

This picture shows the wrong installation of the diagnostic card. Upon the powering on of the computer with this wrong installation, the chips on the diagnostic card will be shorted. Please do double check before the installation.



This is the other wrong installation. The diagnostic card PCIe connector breaker pin needs to be aligned with the PCIe slot breaker pin as well. Installing the diagnostic card on any other spots on the PCIe x16 slot will short the diagnostic card when the computer power is ON.

Orientation Auto-Adjustable Digital Codes Display Unit

- When installing the diagnostic card to the computer PCI or PCIe connectors, the digital codes display units will auto adjust the orientation of the digital display.
- A nice user friendly design.

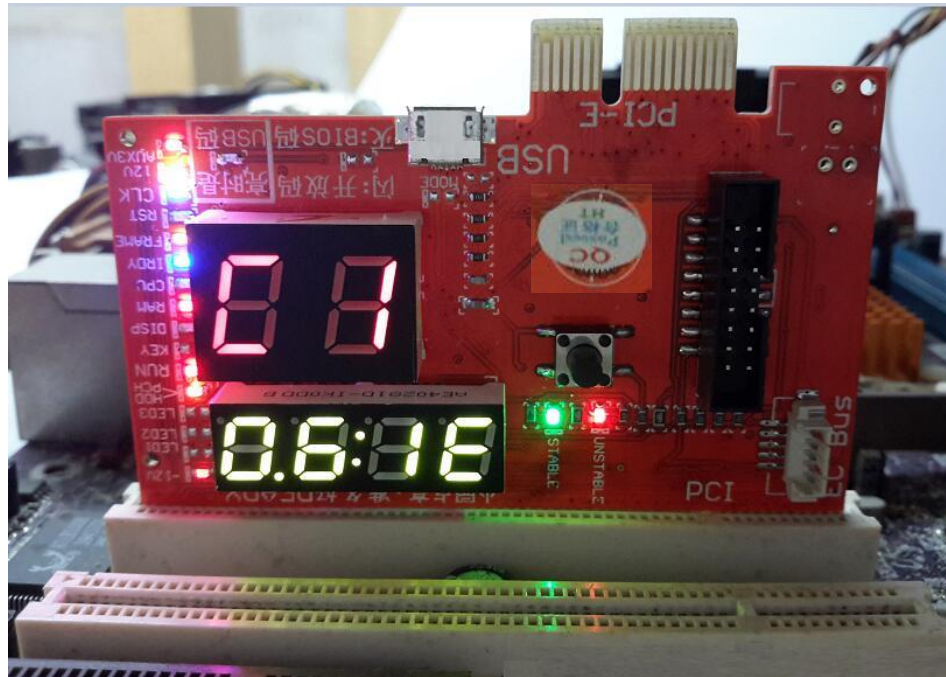

LPC Diagnosis and the Motherboard LPC-Debug Connector

- T-Card uses of the T type LPC adapter that connects to the large master diagnostic card KQCPET6 V6 first then connecting the T-Card to the motherboard to make the auto LPC diagnosis possible and more user friendly. Use this T-Card on the motherboard that comes with the LPC-Debug connector. Please install the diagnostic card corresponding Large or Small LPC connector (as shown in the following right picture) to the motherboard 'DEBUG_PORT' (Please take note that the different motherboards could have named the LPC debug ports differently).



Works on the motherboards 2x5 pins layout LPC debug ports

LPC Diagnosis and the Motherboard LPC-DEBUG Connector

- In order to use the diagnostic kit on the motherboards with the LPC-Debug connectors, please install the diagnostic card LPC connector (please select either large or small LPC pins connector on the T-Card) to the motherboard DEBUG_PORT. Before powering ON, please connect the USB power cable (the smaller micro USB connects to the master diagnostic card, the large USB connect to the motherboard standard USB port), then connect the T-card to the diagnostic card master board using the included extension cable (please see the following picture). Next powers ON the motherboard to wait for the final codes that stop changing.

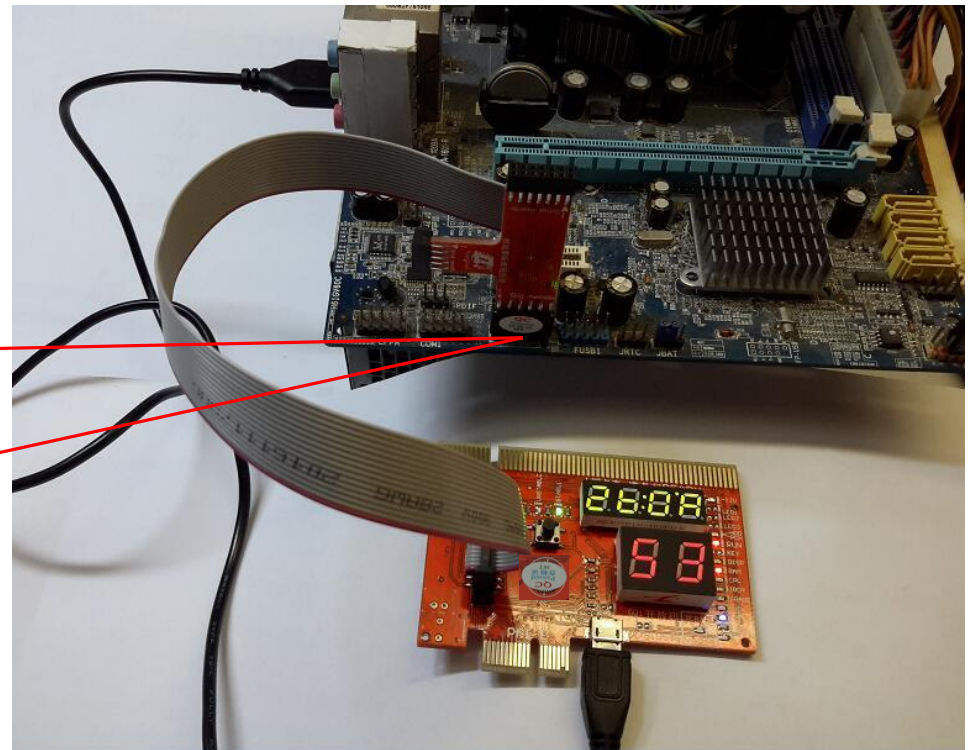

The advantages of using the USB for supplying power to the diagnostic card

- 1. USB ports come with the standard 5v power supply, easy to use;
- 2. not rely on the motherboard LPC 3.3v for the power, can still diagnose the motherboard when the LPC power is faulty;
- 3. reduces the burden to the LPC connector and thus help to maintain accurate diagnosis result;
- 4. the LPC port may have the drop on the voltage due to several factors, using USB can help to supply the stable power for accurate diagnosis;
- 5. helps to prevent the LPC power from overloading and causing the shorts;
- 6. no need to add extra power components to the motherboard. More power components rise the opportunity of damage and shorts to the diagnostic equipments;
- 7. These are just some advantages, more advantages of using USB for power but will not be listed here.

USB Cable

Use this cable for the USB diagnosis feature on the KQCPET6 V6 TypeB diagnostic card. This cable should be connected to the diagnostic card master board MICRO USB connector to diagnose desktop and laptop computers.

When using the diagnostic card on the motherboard LPC connector or MINIPCIE, the USB cable is for getting the electrical power purpose only. To help the motherboard sees the diagnostic card, we need to get the power to the diagnostic card in advanced. So we need to connect the USB cable one end to the diagnostic card and the other end to the same computer USB port before powering on the computer to run the diagnosis. (using the USB power sources other than the same computer motherboard USB port may cause the diagnostic card not working). (the USB cable is only needed for LPC and MINIPCIE diagnosis)

Each set of the diagnostic kit comes with an USB cable, smart phones MicroUSB cable is a compatible substitute.

The actual USB cable includes with the diagnostic card may look slightly different than the one in this picture.



Extension Cable

- The extension cable is used to connect the accessory parts such as the T-card and MINIPCIe adapter to the diagnostic card Master Board
- When testing the desktop PC using the LPC method or testing the laptops using the MINIPCIe connector, uses of this extension cable helps to make the diagnosis much easier and convenient, just like adding the external display that allow viewing of the diagnosis codes more easily.



LPC Universal Adapter (T-Card)

- This T-card comes with 3 different sizes and specs LPC connectors to work on the different motherboards LPC Debug ports.
- The small white triangle marks (please see the spots where the yellow arrows pointing to in the following pictures) shows the 'pin 1' position which needs to be aligned with the same pin 1 of the LPC port on the motherboard. Does not matter using the front side or the rear side pin1 of the T- Card, just make sure the pin 1s are aligned and matching. Try installing the T- card to the motherboard LPC port on each side and see which side gets the different codes running on the master test board.
- When using the LPC diagnosis, select the large LPC pin connector or small LPC pin connector on the T- card first, then install this selected LPC connector to the same pin 1 on the motherboard LPC Debug port. This method applies to all different brand name computers and motherboards.
- LPC (Large and small pins connector) comes with the complete protection design. If the motherboard LPC Debug ports come with over 12pins connection or more, no need to align the pin 1 method as described above, just install the LPC connector to the motherboard LPC Debug port with different pins combination until the different codes are running on the diagnostic card unit.
- To use this LPC universal adapter card (T-card), please use the included extension cable to connect the card to the diagnostic card master board, then connect the included USB cable for power (must use the same computer motherboard USB port, not the other USB power sources such as the smartphone power adapter USB power connector to power the diagnostic card).
- After all, if still not able to get the diagnostic codes running, please contact your seller for the helps and to see if any upgrade is needed.

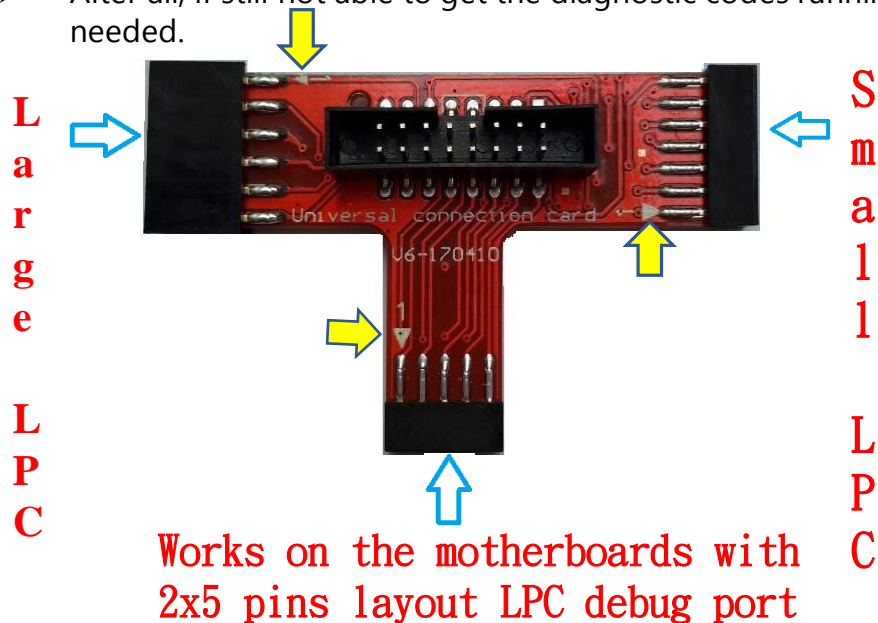

S
m
a
l
l

L
P
C

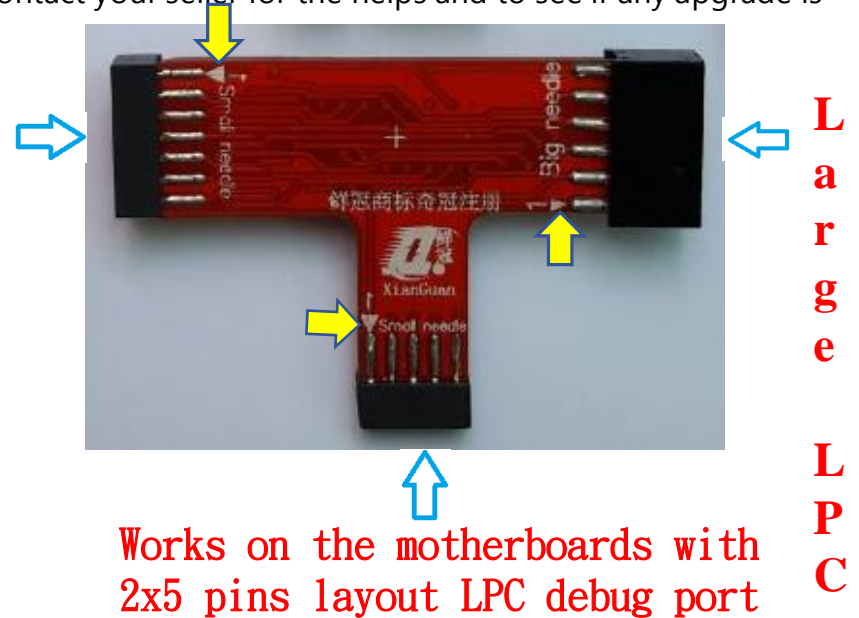

L
a
r
g
e

L
P
C

LPC Fully Automatic Feature

- 'Fully Automatic' means that the diagnostic card can automatically recognize and see the different motherboard LPC ports. The advantages are:
 1. one card fits all, no need any other converters or jumpers
 - a. compatible to the known converted types LPC and the newly invented types LPC connectors. In the case that the LPC debug port is not compatible, need not to buy the extra diagnostic card or another LPC converter card, just need to do the upgrade on the current diagnostic card. The IC chips hardware upgrade and the shipping costs are extra.
 - b. no risk of the extended damages to the computer due to the incorrect connecting of the adapter or jumpers.
 2. No need to pay attention to the brand name or model of the motherboard during the diagnosis.
 3. install the LPC connectors to the motherboard LPC debug port the right way or completely using the other turn around way, the diagnostic card will still work normally. If there are Pin1 marks on the both side of the LPC adapter card, try freely by connecting the LPC adapter to the motherboard LPC debug port without any fix pin orientation. Just try different ways, different pins connections till there are different diagnostic codes running on the diagnostic card.

Installing the LPC Connector on the Motherboard

- On the LPC universal adapter card(T-Card), there is a small white triangle mark highlighting the pin1 on both Large and Small LPC pins connectors. Look for the same pin1 on the motherboard LPC Debug connector. Align pin1s and install the T-Cards to the motherboard LPC Debug Connector (please see the following pictures for the correct installation.)
- **Just pay attention on the pin1 alignments, ignore the missing pin on the motherboard LPC debug port.**
- If installing the LPC connector incorrectly, the diagnostic card will not work, but will not burn or causing damages. Try again until installing the LPC adapter correctly on the motherboard LPC debug port.

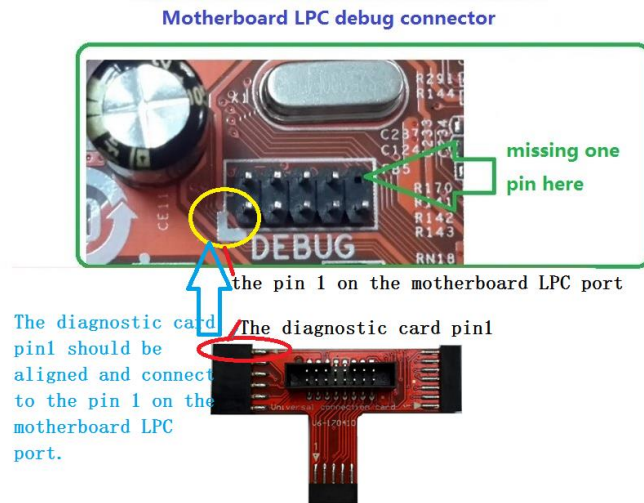

This blocked pin design does not allow the LPC connector to be installed in different way to the motherboard LPC connector, must match exactly the pins position. But motherboard LPC pins layout are not all the same, so we leave this pin unblocked on our cards.

Correct

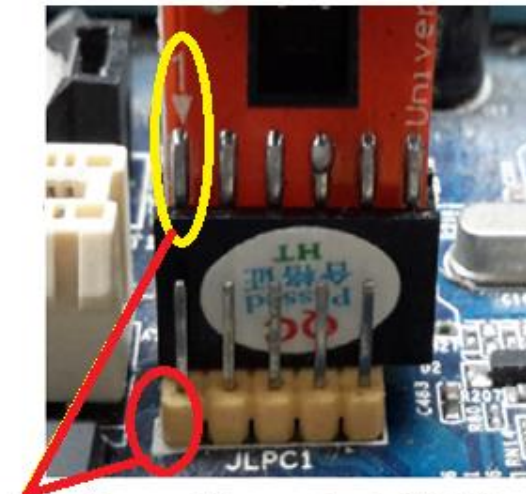

The diagnostic card pin1 (with white triangle sign) should be aligned and connect to the pin 1 on the motherboard LPC port.

wrong

The following installations are all correct

There are situations that the motherboard LPC Debug ports may come with more or fewer pins than the Large and Small LPC pins connectors. Just install and do the diagnosis.

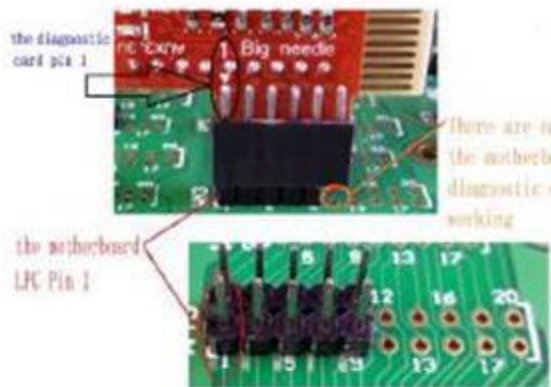

Large LPC Pins 2*5

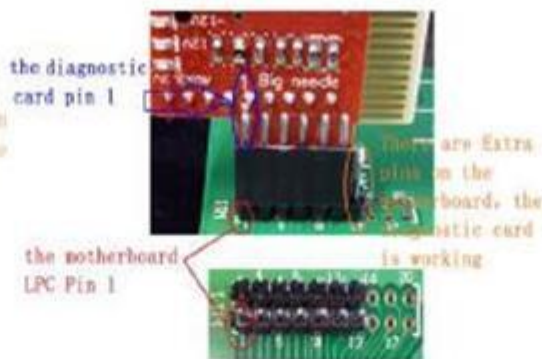

2*7

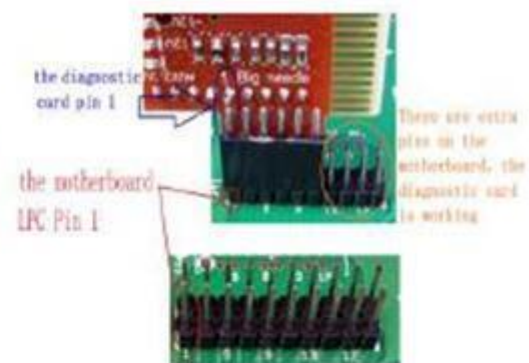

2*10

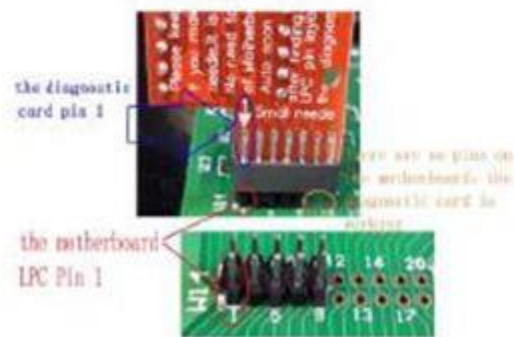

Small LPC Pins 2*5

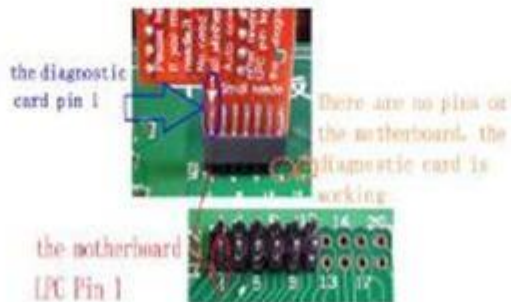

2*6

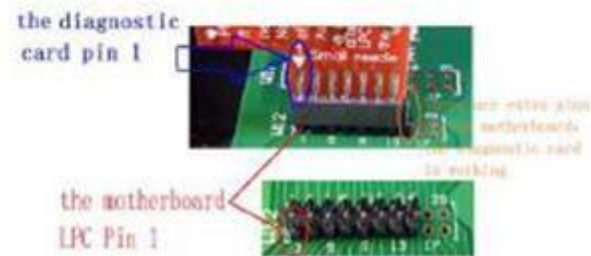

2*8

The LPC Debug Ports on the Motherboards (part 1)

The followings are the known LPC connectors.

Attn: same brand motherboards LPC pins layout could be different



Asus



ECS

bold
mark to
indicate
the pin1



Soyo, Yeston, Colorful, Maxsun, Onda,
Zotac, Wibtek, J&W



Gemen, TongfangPC, MSI

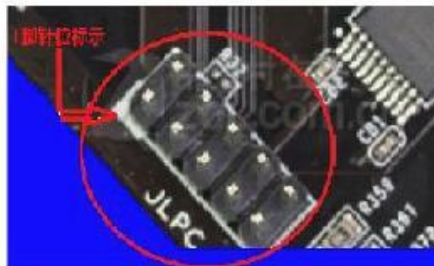

Yeston, Onda, A&W, Colorful, Sapphire,
Maxsun

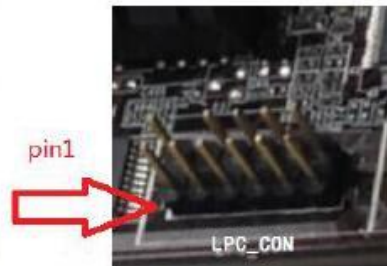

Gigabyte, Asus, MSI,
Jetway, Foxconn, Unika, Pcasl



HP, Pegatron

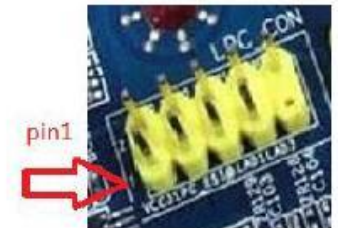

Pcasl



Lenovo, MSI, HP

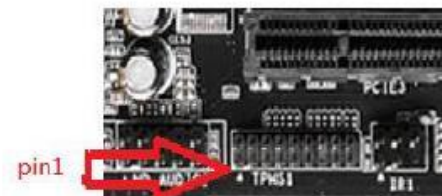

ASRock (New)

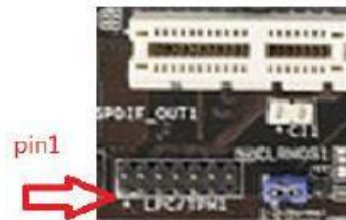

ASRock



Asus, Gigabyte, Foxconn, Jetway, Unika

The LPC Debug Ports on the Motherboards (part 2)

- 1 ∙ Until the time this user manual is being finalized, there are several new LPC connectors being found. We will keep on looking for the new LPC connector types. In the case that there is any new LPC connector not being supported, please contact seller supports for the upgrade info. IC chip hardware upgrade and the shipping costs are extra.
- 2 ∙ Installing the LPC improperly or wrongly will not causing any damages, just causing the diagnostic card not getting the error codes. If not able to locate the pin1 on the motherboard LPC debug port, please try the different LPC pins connections until getting the different diagnostic codes or please contact seller support for more assistance.

Upgrade

When there are “LPC 、 DEBUG 、 TPM” etc connectors on the motherboard but not getting the changing diagnostic codes, please contact the support for upgrade. The IC chips hardware upgrade and shipping postages are extra..

Qiguan reserves the rights of upgrades.

Diagnostic Card - RUN LED Light

- RUN LED light depends on a very few components to work so comes with a very low error rate. It rely very little on the motherboard connector slot to provide the diagnostic LED codes, so even it is installed on the faulty slot and all other LEDs not getting the diagnostic result, this RUN LED may still work. Just stick to the theory that as soon as this LED flashes, the motherboard used to work. Please use this theory to help diagnose the following problems:
 1. Part of the diagnostic card is faulty
 2. The diagnostic card is not compatible with the motherboard
 3. The connector that the diagnostic card being installed on is faulty
 4. The diagnostic card has not installed properly on the motherboard. Or there is poor contacts due to the dirty/rusty diagnostic card pins or connector slot pins.
 5. Motherboard is dead
- 6. Motherboard is executing the other non-diagnosis related tasks.
- As soon as the CPU works, this LED will be ON. If the CPU used to work once and stop now, this LED will remain ON
- To check on if this LED is faulty, please remove the CPU, powers on the computer, if this LED still ON, the LED is faulty.

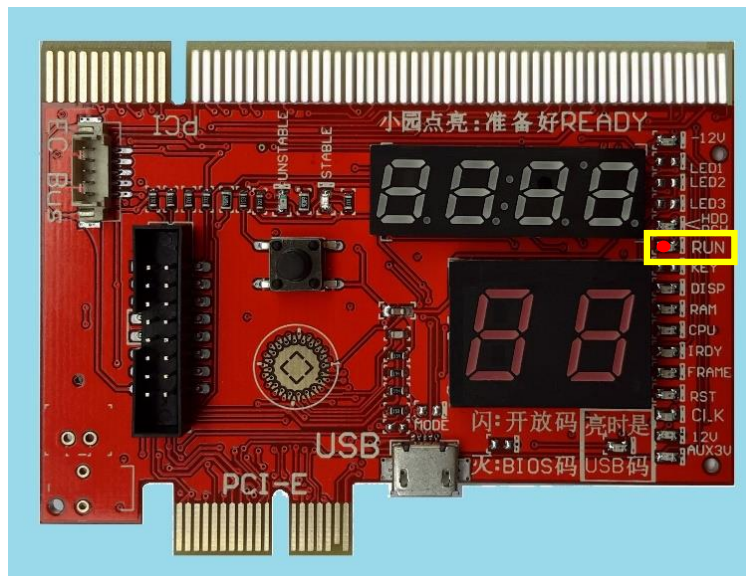

Diagnostic Card- CLK(Clock) Signal LED

- This LED lights ON when there is Clock signal
- Some motherboards will turn this LED OFF after the booting to the Windows.

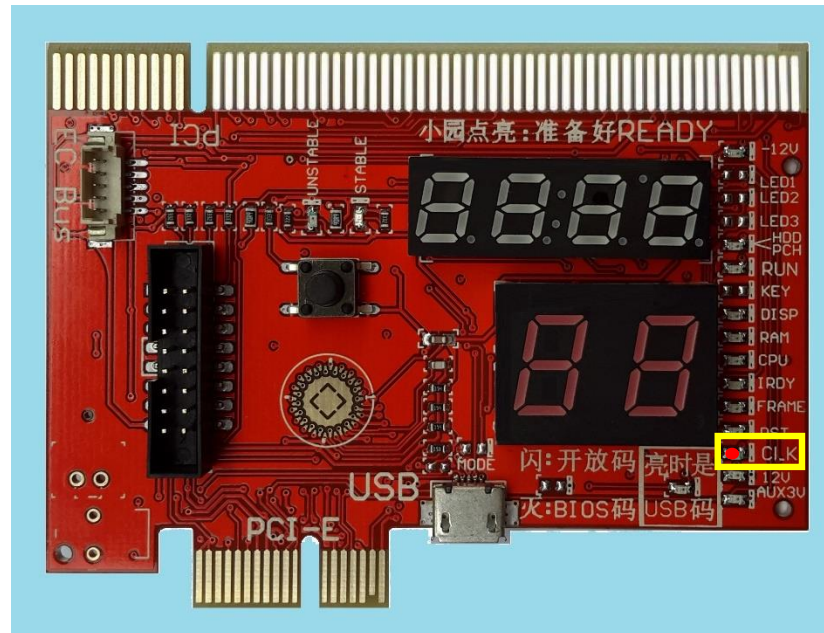

Diagnostic Card-RST(Reset) Signal LED

- When using the PCI slot, this LED reflects the PCI slot reset signal. This LED could take a fraction of the second to flash, most about half a second.
- When using the PCIE slot, this LED reflects the PCIE express slot reset signal.
- When using the motherboard LPC-DEBUG port, this LED could remain steady ON or OFF. Since LPC reset signal cannot represent the motherboard reset circuitry logic, we can ignore this LED when using the LPC diagnosis.
- When using the miniPCIE slot, this LED reflects the miniPCIE slot reset signal, this LED flashes when there is reset activity.

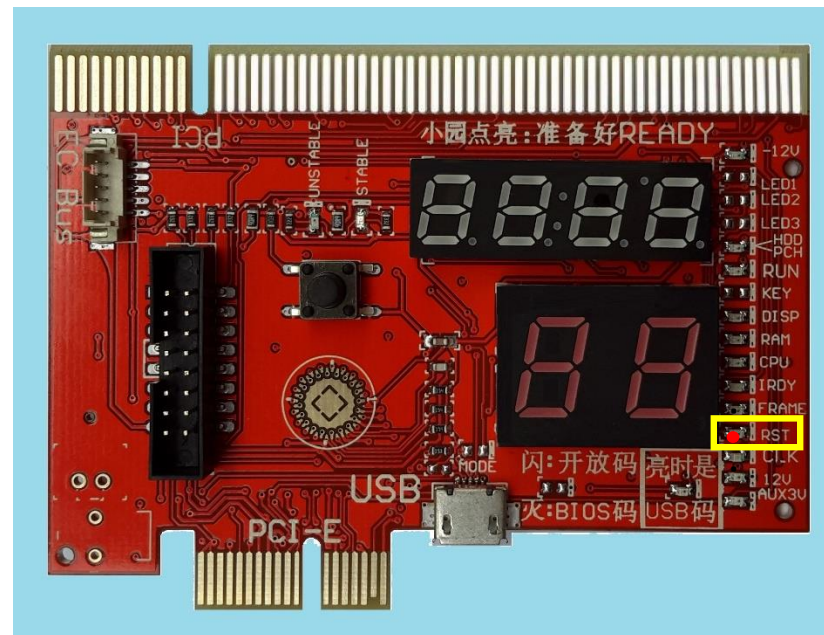

Diagnostic Card – AUX3V LED

- When the computer is connected to the main, no matter the computer is power On or OFF, this LED lights ON when the diagnostic card master board is installed on the motherboard PCI or PCIe slot.
- If this AUX3V LED is dim on boot, please check the Bios settings if the energy saving option is enabled.
- Motherboard LPC port does not have this AUX3V voltage, so this LED will remain OFF on LPC.

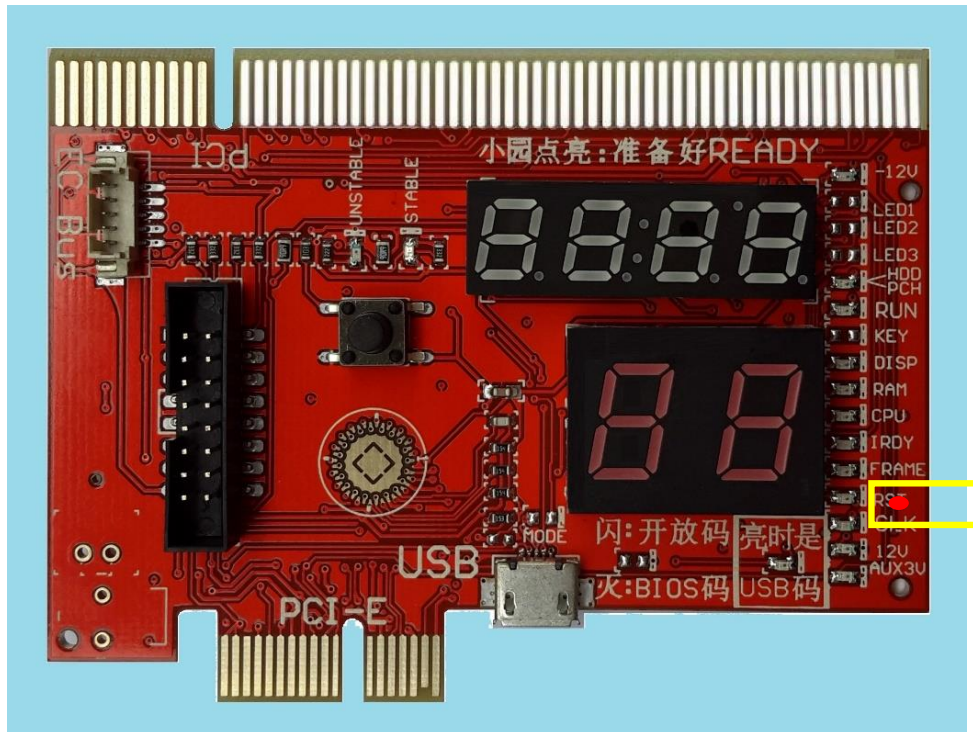

Diagnostic Card– HDD/PCH LED

- HDD/PCH Steady ON indicates that the HDD, North Bridge, South Bridge, USB and SATA etc modules are faulty.

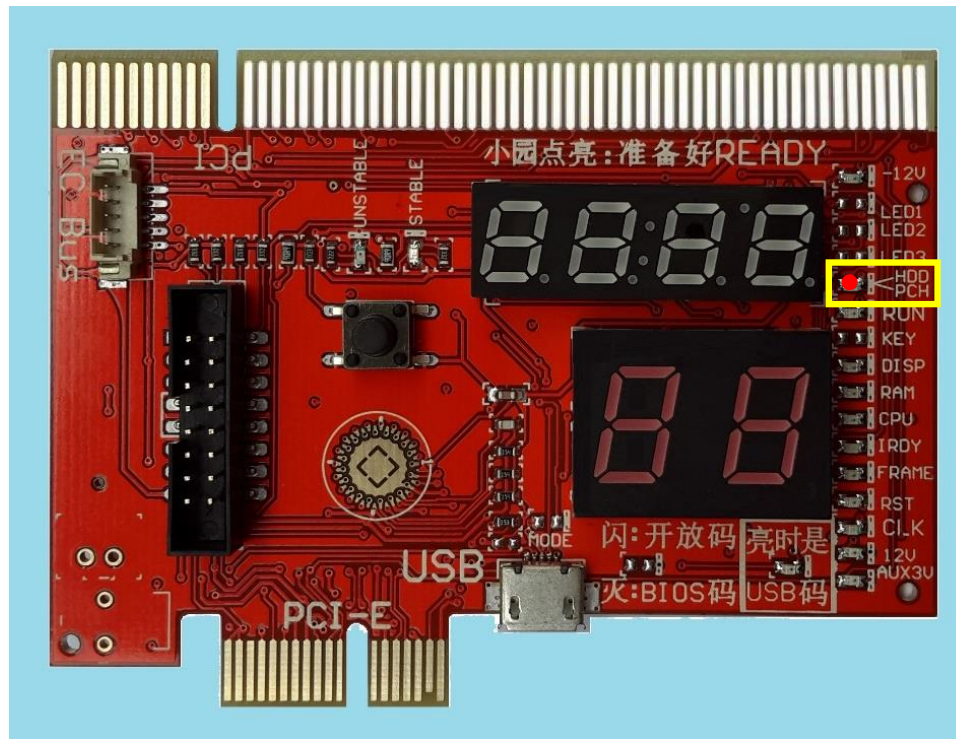

Diagnostic Card – DISP LED

- DISP LED steady ON indicates that the video card is faulty or its driver is corrupted.

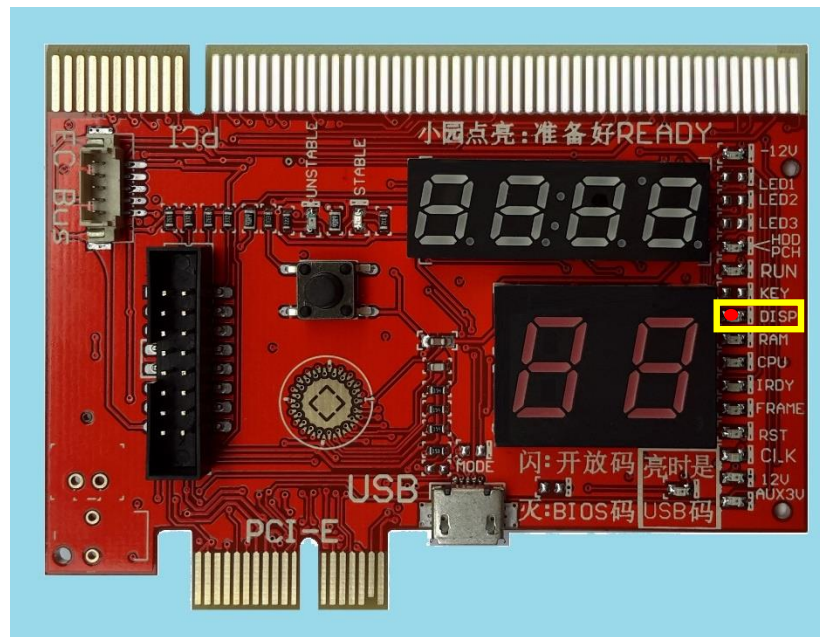

Diagnostic Card – RAM LED

- RAM LED steady ON indicates that the RAM module did not pass the self test.

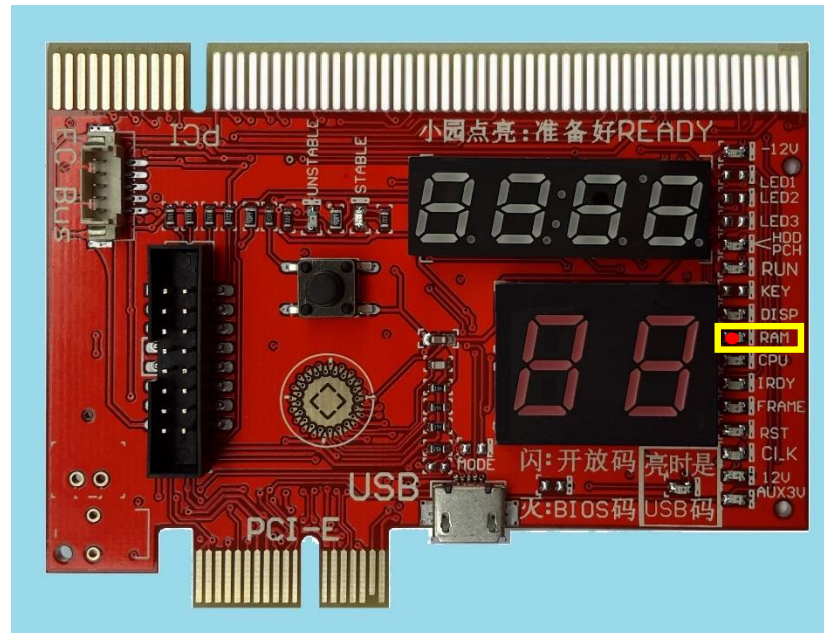

Diagnostic Card–CPU LED

- CPU LED steady ON indicates that the CPU did not pass the self test.

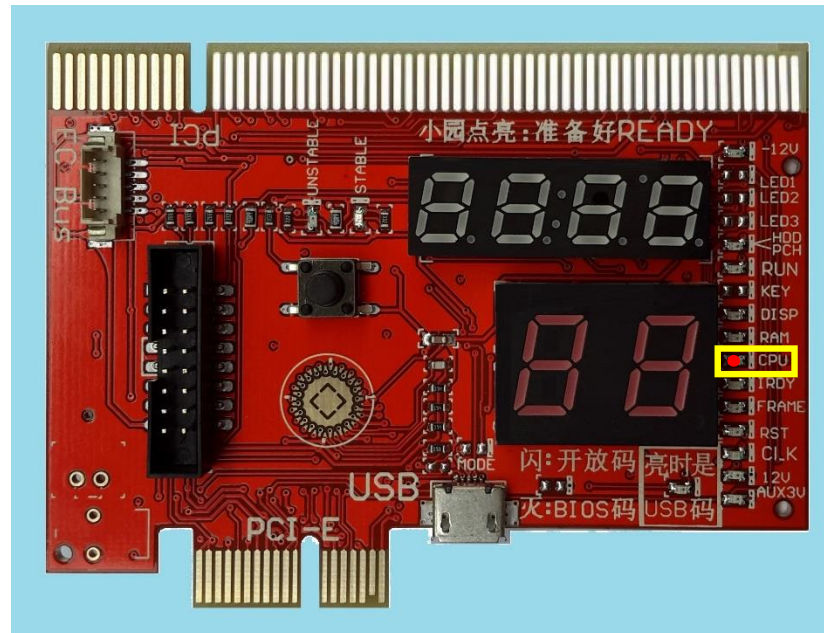

Diagnostic Card – IRDY LED

- IRDY LED OFF indicates there is no IRDY signal (this IRDY signal only present on PCI interface) ◦

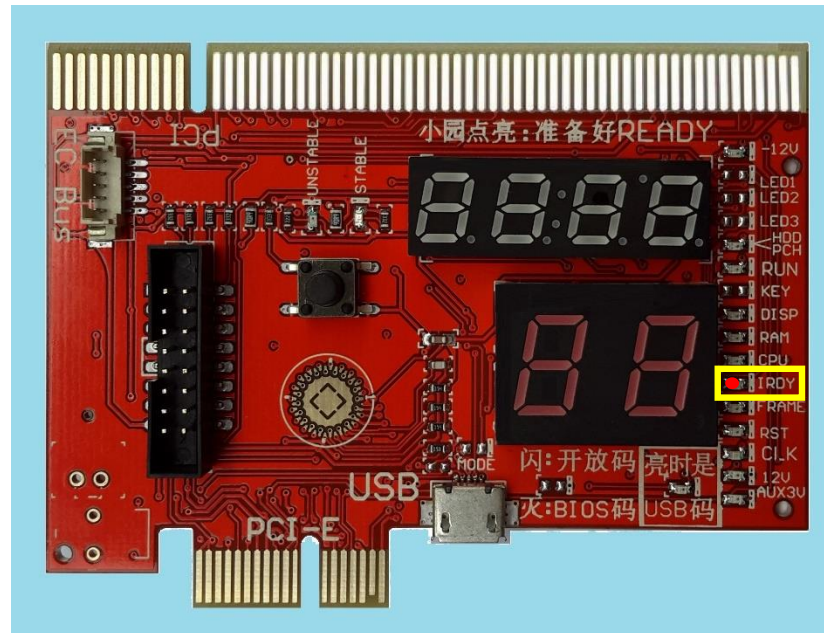

Diagnostic Card – FRAME LED

Improved FRAME LED, this LED flashes when there is cycling FRAME signal.

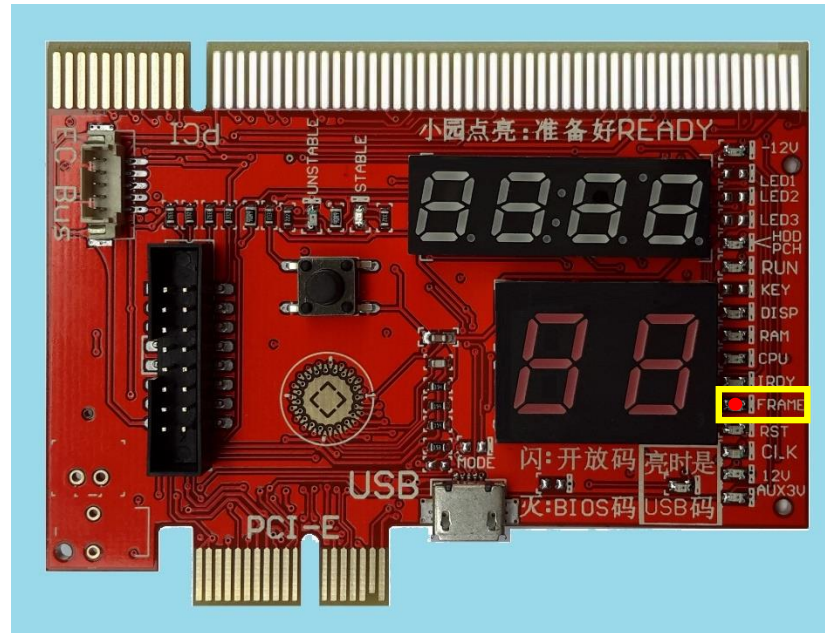

Open Diagnostic Code LED

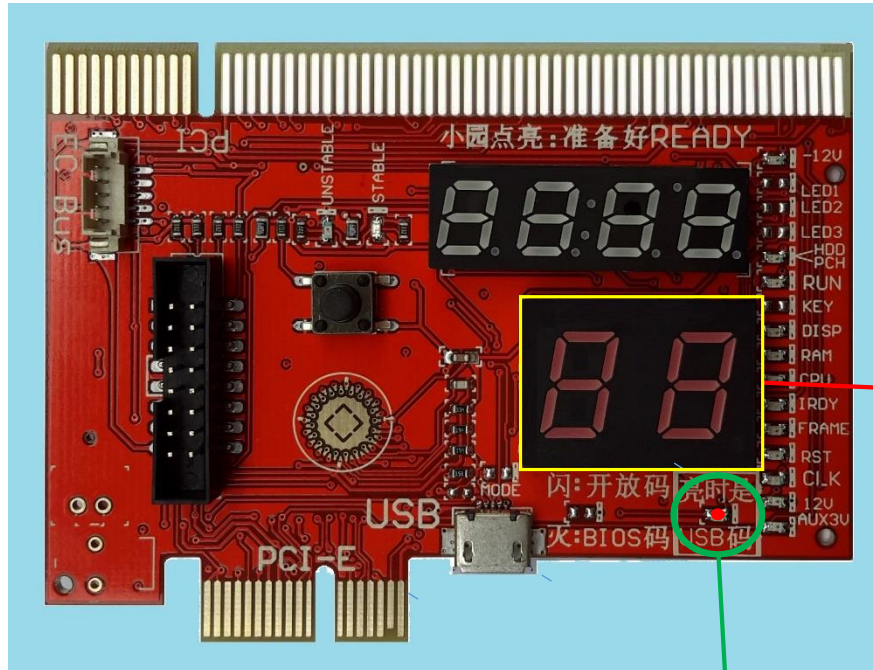

BIOS code /
Qiguan 2digit
open diagnosis
code display
unit
TypeB: USB open
diagnosis codes

- 1.This LED ON indicates above 2digits are USB open diagnosis codes.
- 2.This LED flashes to indicate the above 2digit codes are open diagnosis codes.
- 3.This LED OFF indicates the above 2digits are BIOS POST codes(When the above 2digit showing “no” and this LED also remains OFF, indicating there is no BIOS codes been detected.

MINI PCI-E Adapter Card

- This adapter card needs to be installed on the laptop Mini PCI-E slot which must connect to the LPC bus to start the diagnosis. If there is no LPC bus connected to the Mini PCI-E slot, we need to use wires to connect the IO pins to get the diagnostic codes.(please see LPC fly wire for more info) , not all laptop Mini PCI-E can get the diagnosis codes.
- When using miniPCIE diagnosis and the Bios codes showing 'no' , needs to connect the fly wire to the laptop motherboard to get the Bios diagnosis codes.
- Correct connection:1.please install the MiniPCIE adapter card to the laptop motherboard WIFI MiniPCI connector and use a screw to anchor the adapter card. 2.Next is connecting the MINIPCIE adapter card to the motherboard using the included extension cable. 3.Connect the USB cable (one end to the same motherboard USB connector and the other end connects to the diagnostic card USB connector, powers on the computer to start the diagnosis, please see the following picture for more info. .

7pins fly wire connection socket

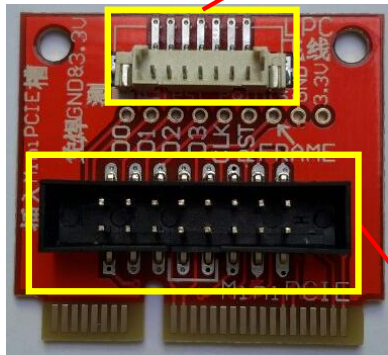

Extension cable socket

MiniPCIE adapter card and Diagnostic Card master board connection

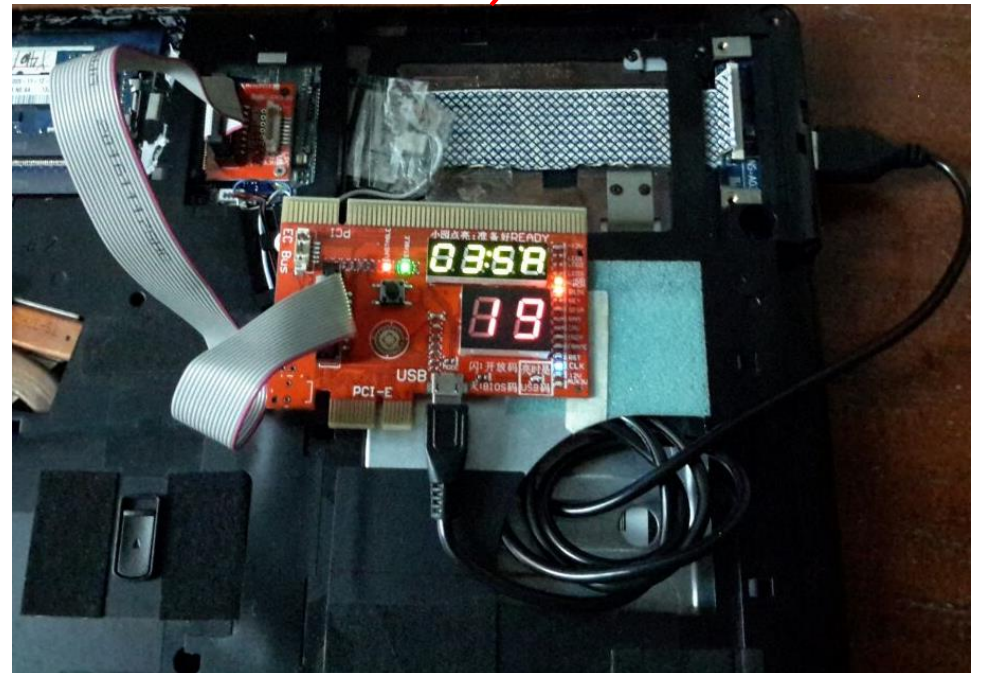

LPC Wire (Fly Wire)

- KQCPET6 V6 diagnostic card allows the connection to the miniPCIE adapter card which supports the LPC diagnosis (please see the followings for more info about this LPC connector) :
- Most of time, laptops do not have the specific connector for this LPC connection directly. So need to use the LPC wire (also called fly wire) to connect the LPC connector on the miniPCIE adapter card to the laptop motherboard.
- If the motherboard comes with PLCC32 BIOS, we can use the LPC wire to connect the diagnostic card to the laptop motherboard LPC connector BIOS. Besides using the LPC Bios connection, we can also connect the diagnostic card to the laptop motherboard LPC connector IC chips. Some commonly seen LPC chips are PC97551, PC87541, PC87591, H8S/2149, W83L950D, TCPA etc.
- The followings are some examples of the laptop IC chips LPC pins, more info please visit the IC chip data guides.
- How to connect? Please use the included LPC wire plug to the MiniPCIE adapter card LPC wire socket, the other end of the LPC wire need to follow the instruction to be welded to the laptop motherboard LPC connector corresponding IC chip pins. The following picture shows the MiniPCIE part.

This method is only recommended for the professional chipset level repair technicians, not for personal repairs!

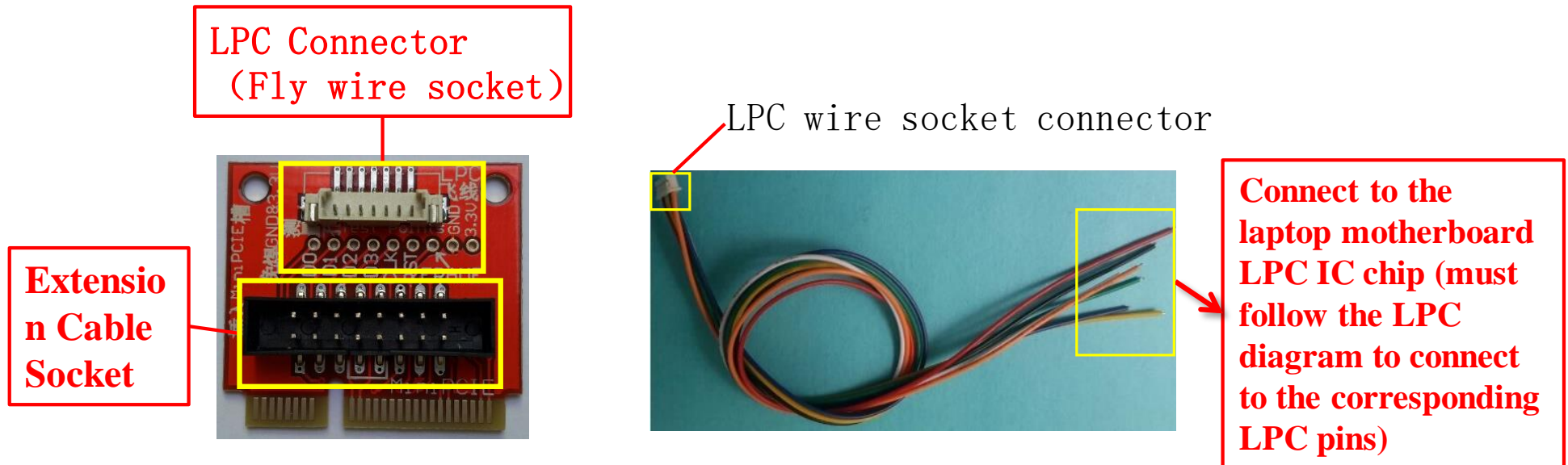

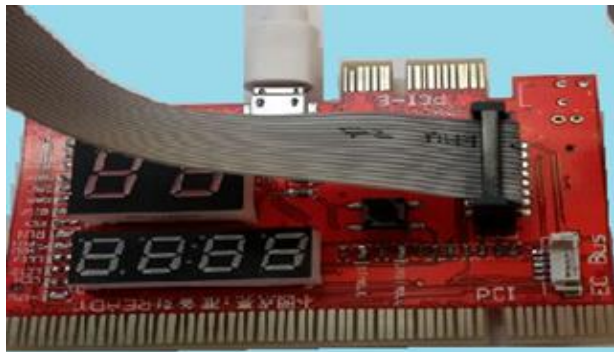

These small holes can be used by the multimeter to measure

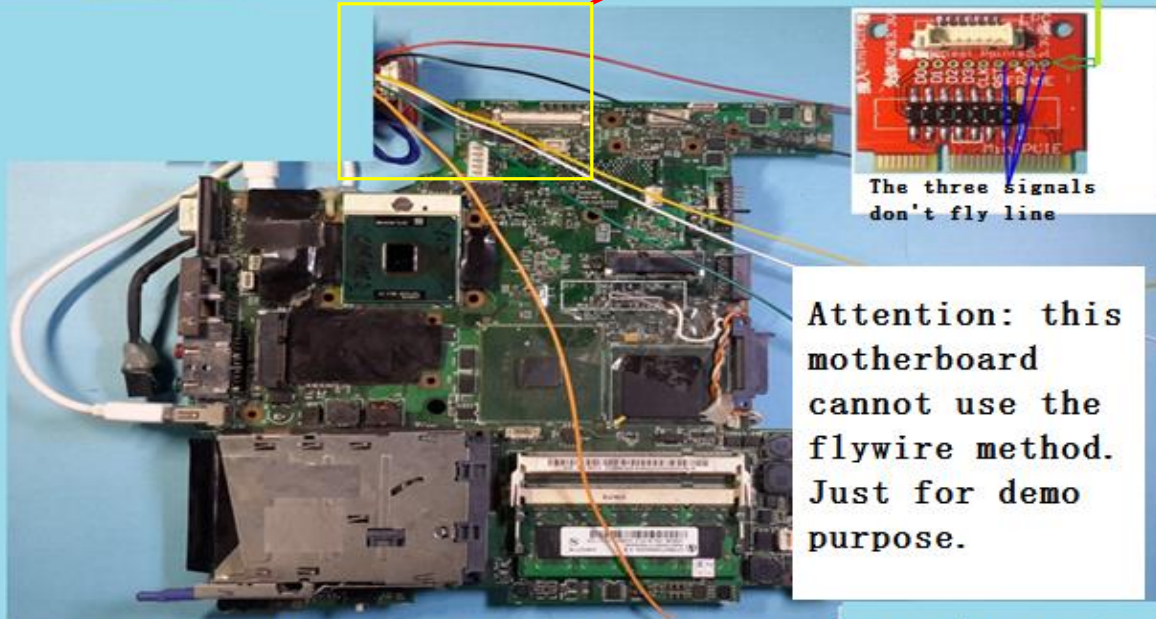

Attention: this motherboard cannot use the flywire method. Just for demo purpose.

1st step:Double check to make sure the motherboard does not come with the diagnosis connectors.
2nd step:Use the USB wire to connect the diagnostic card and the motherboard USB port.
3rd step:connect the miniPCIe adapter card D0, D1, D2, D3, CLK, Frame signal flywire to the motherboard corresponding pin connection(needs welding)
Do not weld the RST signal wire, diagnostic card does not rely on this signal, GND and 3.3v also not needed since USB provides the power.
saves hassle of welding these 3 wires and helps to reduce the errors.

LPC wire (Fly wire) method is only recommended for the professional.
chipset level repairs, do not try without proper knowledges.
Improper uses will cause the damages to the motherboard and the diagnostic card.

EC Wire

- This wire uses specifically on the laptop motherboards with the EC DEBUG port.
- This wire connects the diagnostic card to the laptop EC connector.



EC wire

EC connector
(5pins connector)

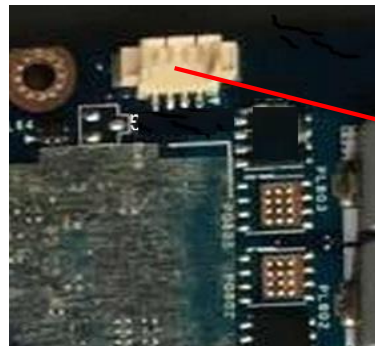
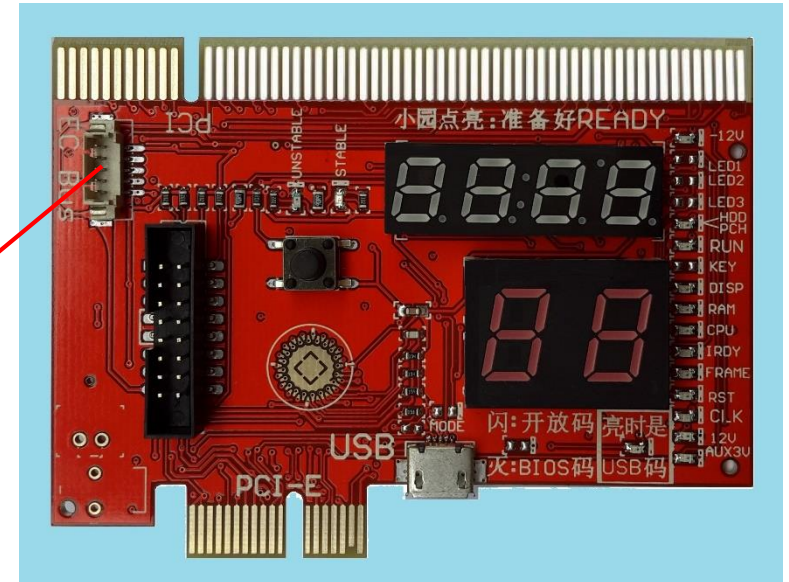

4pins laptop
motherboard EC
connector

BIOS Diagnostic Codes

- BIOS codes comes with 2digits. These 2digit Bios code descriptions were defined by the Bios manufacturers, also called the traditional diagnosis.
- Use the diagnostic card on the PCI/PCI-E/MiniPCI-E/LPC connectors, we can see the each connector' s Bios code. But not all motherboards diagnosis get the Bios codes.
- When this diagnostic card is installing on the above connectors, the Bios Code digits showing " no " and the small dots on the same 2digits keep flashing, this indicates that the current slot connector does not have the Bios codes AND no Qiguan open diagnosis codes as well. Please be advised to install the diagnostic card to the motherboard other connectors and do the diagnosis again. Also please look for the 4digit Qiguan codes for descriptions.

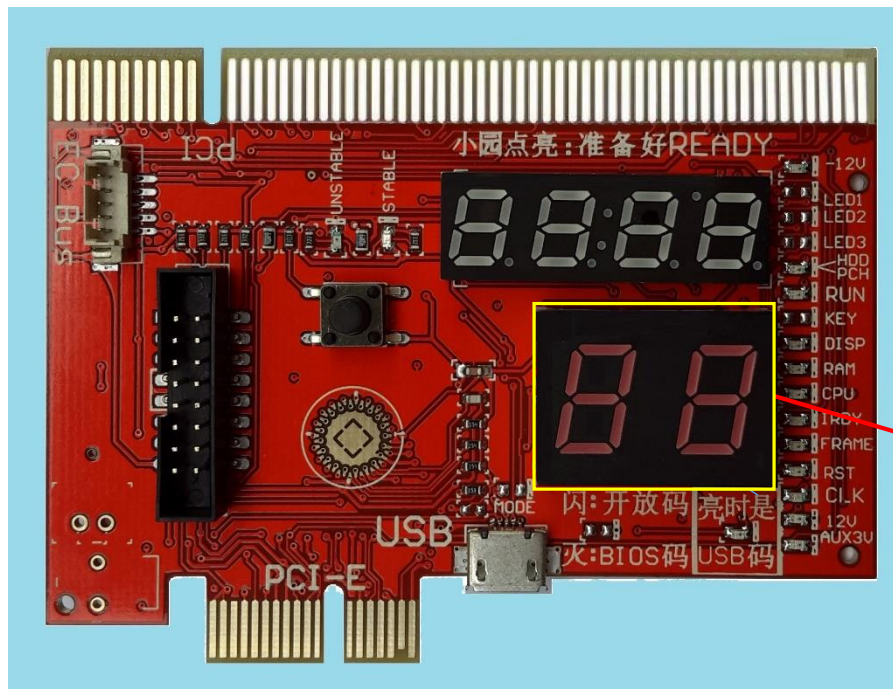

BIOS Codes/
Qiguan 2digits
open diagnosis
code display unit
TypeB card: USB
open diagnosis
codes

Traditional Diagnosis Features

- 1. Comes with the AUX3V 、 +12V 、 -12V Power LEDs and CLK 、 RST 、 FRAME 、 IRDY 、 RUN signal LEDs. Capable of showing the blank screen motherboard repeated auto reset faults that leads to the No POST and dead machine.
- 2 . Completely eliminated the onboot random codes. No more difficulty in distinguishing between the machine startup initialization codes and the diagnostic error codes.
- 3 . Allows the checking of some important motherboard activities even when the CPU is not installed on the motherboard.
- 4 . Supports 80h 、 84h 、 300h ports simultaneously.
- 5 . Allows the diagnosis to be completed at one time without any interruption. Improved performance and stability.
- 6 . The diagnostic card with the best compatibility ever made. Capable of diagnosing all high-end and low-end motherboards. (Including Intel 、 AMD 、 VIA etc all series with servers motherboards) , comes with very high diagnostic accuracy and the stability.

Qiguan 2digit Open Diagnosis Codes Features

- These 2digits Diagnosis apply to the PCIe and MiniPCIe Slots
- As shown in the following picture, when the small dots steady OFF/not flashing, the diagnosis codes will be the Bios Codes.
- When the small dots flashing, the diagnosis codes will be the Qiguan 2digit open codes.
- When showing “no”, small dots flashing, there is no Bios Code and no Qiguan open codes as well.
- **TypeB** card when connect to the USB and no diagnostic codes coming from any other bus connector, the diagnostic card will show the USB open codes.

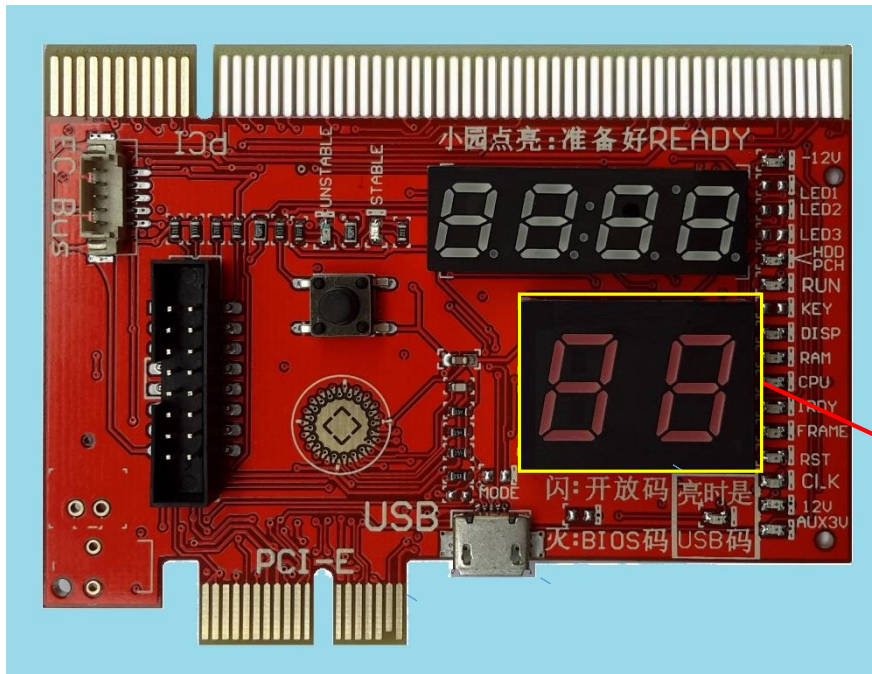

BIOS Codes/
Qiguan 2digits
open diagnosis
code display unit
TypeB card: USB
open diagnosis
codes

How can the end user collect Qiguan 2digit open diagnosis codes?

Please submit the following info to the Qiguan support, we will send you the new latest smart phone app with more codes descriptions free.

- Uses of the standard computer motherboard to collect the following info: a.take the picture of the motherboard model number. b.power off the PC and remove the RAM modules. c.install the diagnostic card to motherboard then power on the PC d.Take the photo of the codes on the diagnostic card(must showing in the photo that the RAM modules been removed)
- Collect the open codes during the PC diagnostic process (before the repairs) : a.take photo of the motherboard model number · b take record of the 2digit open codes ;c.install the diagnostic card to the other bus connector to test the motherboard or use other methods to repair the computers. After the repairs, if reaching the similar problem on the other computers,just need to check on the earlier recorded diagnosis codes, we can solve the computers with the similar symptoms quickly.

When displaying 'no' , the small dots on the digital display flashing, this motherboard does not have the open codes, please be advised to install the diagnostic card on the other PCIe connectors to do the diagnosis again.

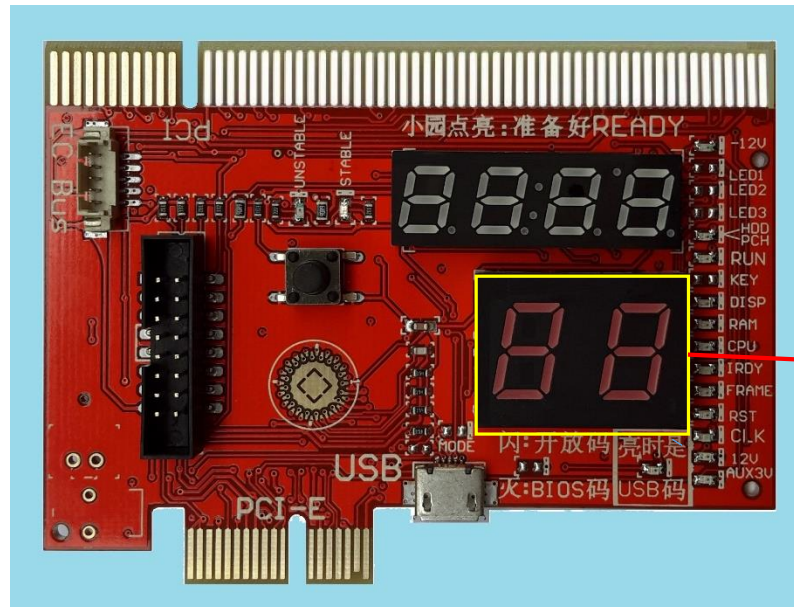

BIOS codes/
Qiguan 2digit
open codes
display unit

Smart Phone End User App —2digit Qiguan Open Codes Demo Pictures

We are developing the Smart Phone App now. Please see our new latest APP version soon, the picture below is for reference.

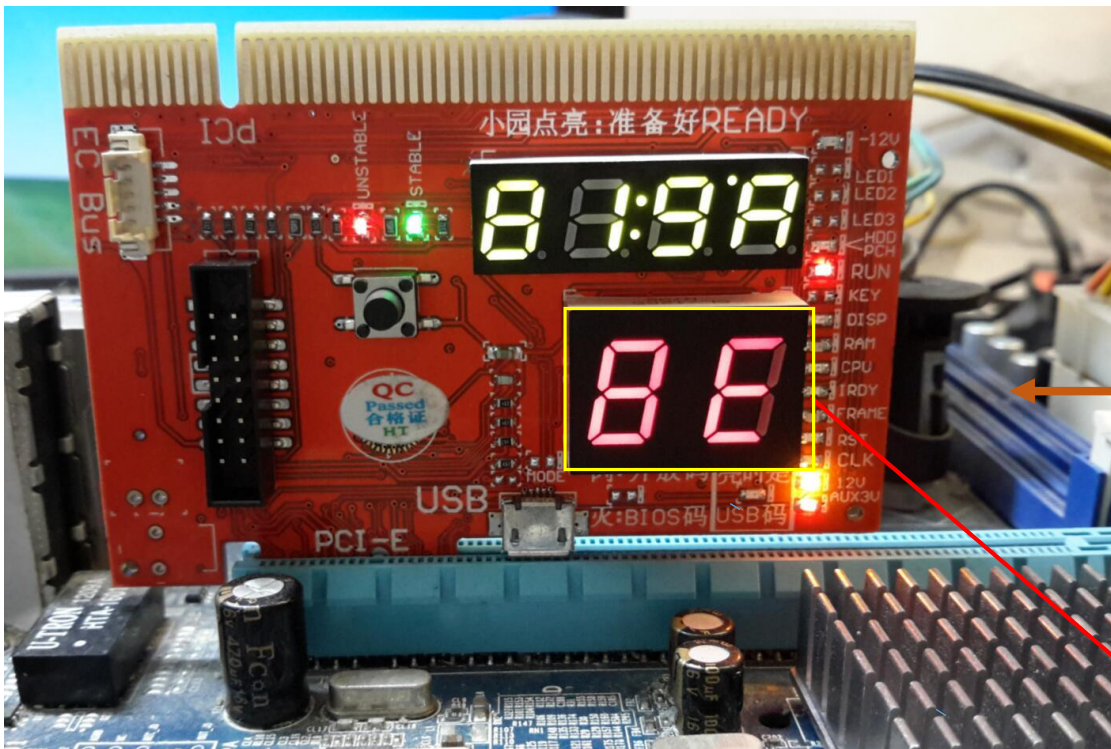

No RAM installed

Qiguan 2digit open code display unit. This time, we can see the codes 8E on a motherboard without RAMs.

Qiguan 4digit Diagnostic Codes

Assistance to the Novice and the Handy Tools to the Professional

- 1 · Consistently checking if the diagnostic card is error-free. Generates the codes to warn user if the diagnostic card is faulty. Avoids inaccurate diagnosis.
- 2 · CPU affects the most traditional diagnostic cards working condition. Qiguan diagnosis helps to find out the factors that causing the non functional traditional diagnosis. Helps to restore the traditional diagnosis by fixing the errors.
- 3 · Qiguan diagnosis does not rely on the BIOS version info. The Qiguan diagnostic codes are clear, complete and accurate. Complete checking on the BIOS POST Codes properties. Reduces the traditional diagnostic card faults.
- 4 · Technology breakthrough the traditional diagnostic card limitation. Besides allowing the PCI 、 PCIE 、 LPC 、 MiniPCIE advanced interface diagnosis connections, it also creates many sections to help improve the diagnosis accuracy and reliability.

Qiguan 4digit Diagnostic Codes

- Qiguan Diagnostic Codes are 4digits Hexadecimal codes. Designed, Defined and Developed by Qiguan. It is different from the BIOS codes. Each of the Qiguan Diagnostic Codes comes with the corresponding definitions. There are some 4digit codes defined differently on the diagnostic card KQCPET6 V6 than the KQCPET6-H V1/V2 cards. If have any question, please contact Qiguan support.
- The diagnostic card will show the corresponding 4digit Qiguan codes when being used on the different interface connectors.
- Qiguan diagnostic codes allow the user interactive checking option.---- The smart phone App. Use the smart phones to scan the QR code or download the APP files for the installation, allows quick check of the codes anytime anywhere.

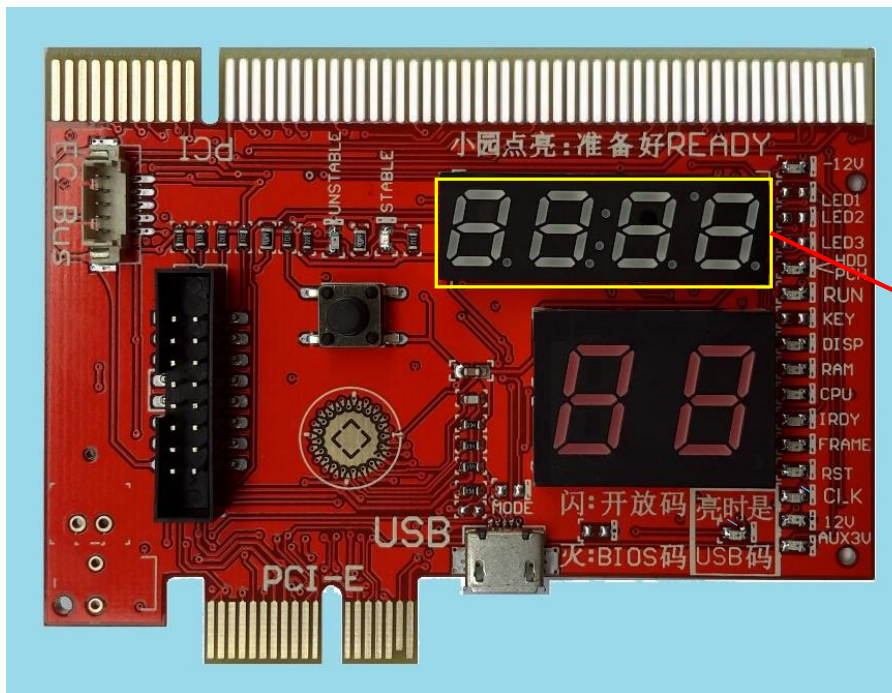

4digit
Qiguan
Codes
Display
Unit

Diagnostic Code Descriptions Lookup Method 1

Uses of the smart phone APP, **Android(available) and Apple IOS(pending).**

Uses of the browsers on the smart phones or any QR code scanning APP to scan the QR code sticker on the diagnostic card, then installing the APP easily on the smart phones.

Use the email service to receive the Qiguan installation files, download then install.

Diagnostic Code Descriptions Lookup Method 2

If need help looking up the diagnostic code descriptions and the suggested solutions, please visit our company web link :

[Http://www.Qiguaninc.com](http://www.Qiguaninc.com), Scan the QR code to install the Qiguan Diagnostic Card User Guide - - Smart Phone App.

If there is no computer but smart phone to download the file, we can directly send the Android App file for the installation, no need to use the QR code.

Apple IOS APP is currently under development, please use the Android for now. ◦

Diagnostic Code Descriptions Lookup Method 3

For those users with Apple IOS or PC, still can use the Android App:

If there is no Android smart phone, no tablet PCs, we can still get the Android App to run on PC computers. We will need to use the App helper Software to achieve this!

Diagnostic card– Unstable\Stable\Ready LEDs

- Qiguan diagnostic cards unique stability test feature is indicated by 3 parts, just need to follow the stability test procedure in the next page to complete the test. The 3 parts are Unstable\Stable\Ready LEDs(the last part 'Ready' will be indicated by the 3 small dots as shown in the following picture(so total 5 dot LEDs to check).

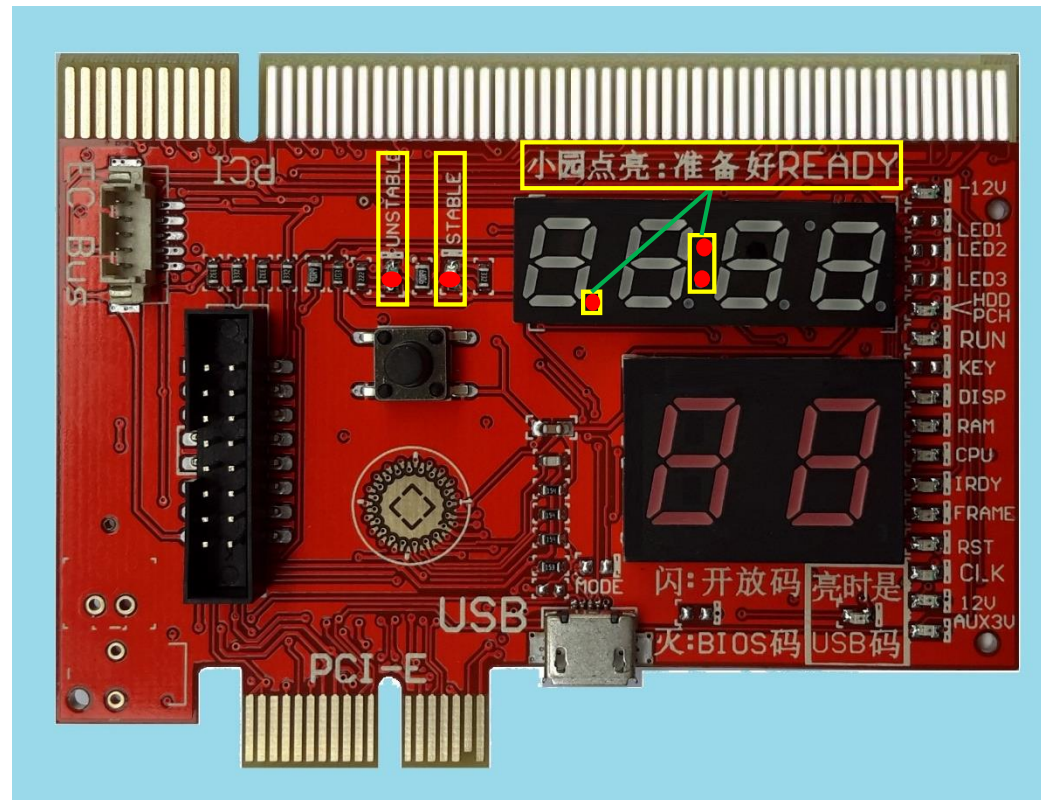

Stability Test Flowchart

■ Figure 2 stability-test flowchart

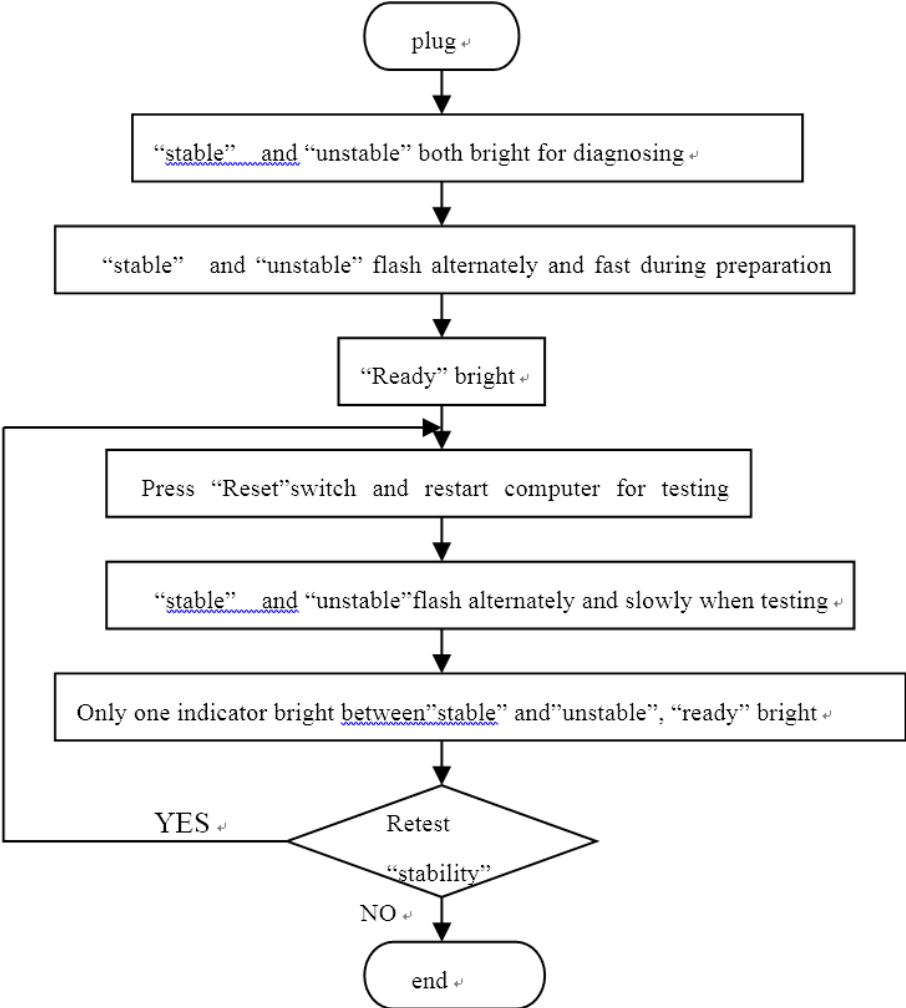

Stability Test Features

- 1. Stability test results will be given as 'Unstable' and 'Stable' 2 LEDs, clear and straight.
- 2. Independent Stability Test can be done by the guide of the flowchart or the 4digit Qiguan codes. Can be done as needed.
- 3 · Besides testing the working computers stability, also test if the faulty computers contains the fixed faults or variable erros. Eg. Semi faulty computers that sometimes working, sometimes not with hidden hardware errors. This test helps to find out the faults and eliminate the errors.
- 4 · This feature can be used to help selecting the computer or the computer parts. It can help the users in buying the computers or purchasing the quality accessories parts such as RAM, HDD, keyboard...etc) as well as the peripherals such as UPS, printer, USB devices and ATM machines...etc. Also helps the computer vendors to set the prices correctly for the stable computers.

The Diagnostic Code “no”

The Bios diagnostic codes showing “no” indicates that there is no Bios POST code been received. Same as the initialization codes of the diagnostic card.

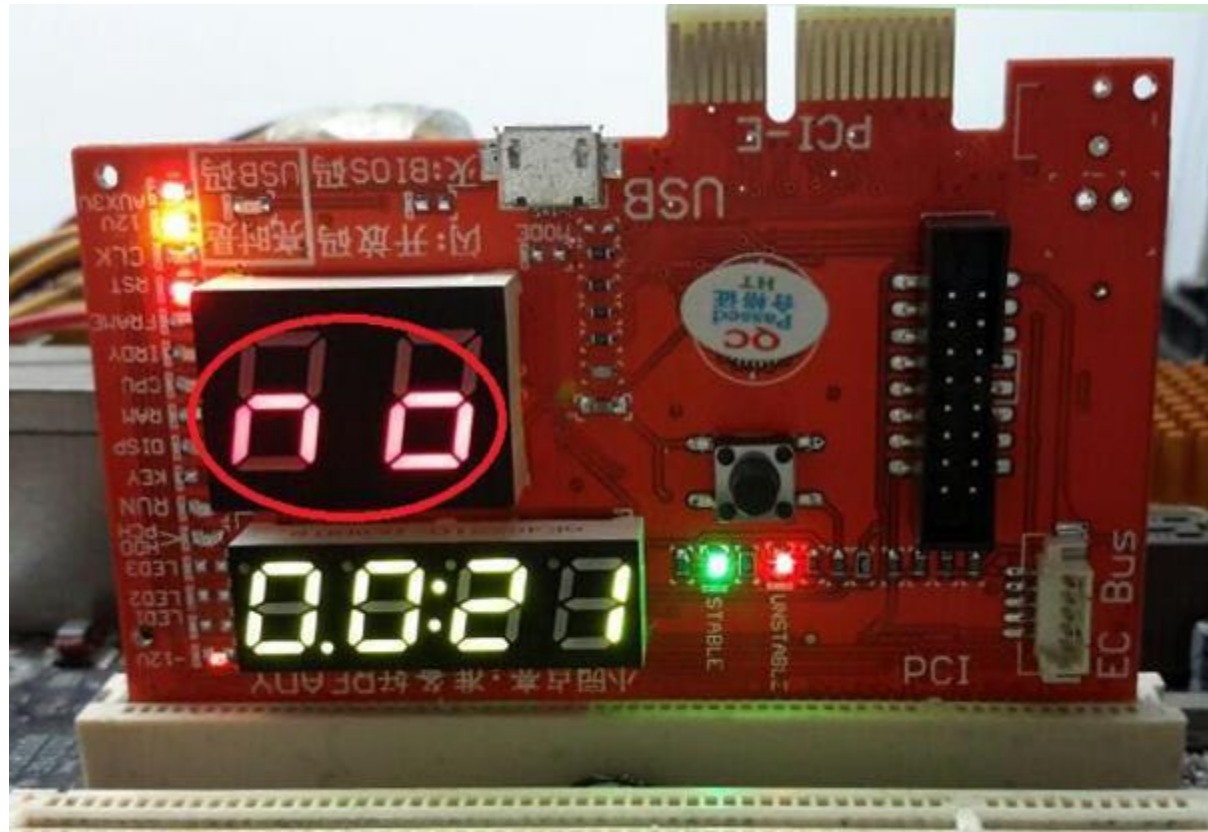

What to do with this Bios Code 'no' when the diagnostic card is installing on the PCI slot?

1. Showing POST code 'no' when the diagnostic card is not properly installed on the motherboard.

solution: ① Clean the diagnostic card pins by using a paper rubber ② There is dust, rust or oxidations on the motherboard slot. Please clean the slots and reseat the diagnostic card a couple more times. Check the slot pins for any loose, bent or broken pins. All these situations will cause the improper contacts so that the diagnostic card will not be able to perform the diagnosis or giving an inaccurate diagnostic results. If there is poor or no contact of the pins, the diagnostic card will show the following symptoms: blank display no diagnosis display, no Bios Code / wrong code, LEDs remain OFF, normal Qiguan codes will be reported as none .

2 . When CPU never worked, the codes will show 'no' and the RUN LED remains OFF

Solution : Motherboard did not initialized, check if CPU is faulty, check CPU jumpers and settings, check PSU voltages, motherboard CMOs battery.

3. Some empty motherboards without RAM, RAM failed the self test or RAM incompatibility, the Bios codes showing 'no'.

Solution: Clean the RAM pins with a paper rubber, clean the RAM slots, reseat the RAM properly. Observe if the diagnostic codes are getting the new codes.

4. The motherboard Bios is faulty

Solution : Refresh / reprogram the BIOS.

5. Computer works normally, still showing 'no';

Solution : If still showing 'no' after checking all pins contacts are good, the motherboard slot is not getting the BIOS codes, please be advised to use the diagnostic card on the other motherboard slots (LPC/PCI) , or on the other motherboards, as soon as any other slot or motherboard gets the different codes than 'no', the diagnostic card is a working unit.

6. Qiguan codes (Only applies to the Qiguan diagnostic card with 4digit Qiguan diagnosis) already indicated those factors that causing Bios codes 'no'.

Solution : Correct the errors reported by the Qiguan diagnosis codes.

What to do when the codes showing 'no' on LPC connection diagnosis?

- 1.First check on the motherboard LPC connector to make sure it is marked any of the followings: LPC_DEBUG 、 LPC 、 DEBUG 、 LPC1 、 DEBUG PORT 、 JLPC 、 LPC_CON 、 LPC-DEBUG 、 LPC/TPM1 、 JTPM1 、 TPMS1 、 TPM etc. dual rows of the LPC pins;
- 2.Next look for the 'pin1' on the motherboard LPC debug port.
- 3.Double check the above 2 checks are correct, then select either large or small LPC connector and align the pin 1 to install the LPC connector on the motherboard LPC debug port.
- 4.check if the USB power cable is in advance connected to the diagnostic card which will be installed on the motherboard LPC debug port.
- 5. Then powers on the computer, if still showing "no", motherboard LPC pins could have the oxidations or poor contacts, just need to power off and reseal the LPC connectors a few more times to help get rids of the oxidations and rust for better pins contacts.
- 6.CPU never worked and showing 'no'and the diagnostic card RUN LED remains OFF. ;

Solution : First check if there is any CPU open circuitry. Check if the CPU is getting the power and heating up after power on.

- 7. Some empty motherboards without the RAM installed or the RAM failed the self test / RAM incompatibility will show the code 'no', please try use the paper rubber to clean the RAM pins, clean the RAM slots, reseal the RAMs and check if there is any new diagnostic codes.

- 8. motherboard BIOS faulty

solution : refresh or reprogram the Bios and try again. If not familiar with the motherboard BIOS refresh, please do not do this.

- 9. Computer works normally, still showing 'no';

Solution : If still showing 'no' after checking all pins contacts are good, the motherboard slot is not getting the BIOS codes, please be advised to use the diagnostic card on the other motherboard slots (LPC/PCI) , or on the other motherboards, as soon as any other slot or motherboard gets the different codes than 'no', the diagnostic card is a working unit.

- 10. Qiguan codes (Only applies to the Qiguan diagnostic card with 4digit Qiguan diagnosis) already indicated those factors that causing Bios codes 'no'.

Solution : Correct the errors reported by the Qiguan diagnosis codes.

What to do when the codes showing 'no' on PCIE connection diagnosis?

- The 2digit codes showing 'no' on the PCIe connection diagnosis indicates that the diagnostic card is not getting the BIOS Code and not getting the Qiguan 2digit open codes as well.
- 1.on the motherboards with both PCI and PCIe connectors, please use the PCI as priority, this is because the motherboard manufacturers could have designed one of these connectors to outputting the BIOS codes, while the other connector will not have the Bios codes.
- 2.When the motherboard does not come with PCI but PCIE slot, the diagnostic codes showing 'no', the followings are the 2 possibilities.
 - a. there is other BIOS diagnostic port such as LPC connector on the motherboard. Please use the LPC diagram guide in this manual to help checking if there is LPC debug port on the motherboard, if so, please use the LPC diagnosis instead.
 - b. If there is no other LPC debug port but only the PCIe slot, the motherboard has no Bios codes sent to its PCIe connector, we can do the followings:
 - ①CPU never worked with the bios codes 'no' and the RUN LED remains OFF.

Solution : First check if there is any CPU open circuitry. Check if the CPU is getting the power and heating up after power on.

- ②. Some empty motherboards without the RAM installed or the RAM failed the self test / RAM incompatibility will show the code 'no', please try use the paper rubber to clean the RAM pins, clean the RAM slots, reseal the RAMs and check if there is any new diagnostic codes.

- ③. motherboard BIOS faulty

solution : refresh or reprogram the Bios and try again. If not familiar with the motherboard BIOS refresh, please do not do this.

- ④. Computer works normally, still showing 'no';

Solution : If still showing 'no' after checking all pins contacts are good, the motherboard slot is not getting the BIOS codes, please be advised to use the diagnostic card on the other motherboard slots (LPC/PCI) , or on the other motherboards, as soon as any other slot or motherboard gets the different codes than 'no', the diagnostic card is a working unit.

- ⑤ .Qiguan codes (Only applies to the Qiguan diagnostic card with 4digit Qiguan diagnosis) already indicated those factors that causing Bios codes 'no'.

Solution : Correct the errors reported by the Qiguan diagnosis codes.

Q & A

- 1、 There are so many diagnosis connectors, how to assure the diagnostic accuracy?
- Answer: Diagnostic card can automatically identify each different connector and generate the diagnostic codes, the diagnosis results will not be affected by the numbers of different diagnosis connectors.
- 2、 TypeA diagnostic card uses USB for power purpose only, if need to get the USB open codes on Type A cards, what can be done?
- Answer: Only TypeB diagnostic card comes with this feature, please use the TypeB card for this purpose.

Q & A

- 3、 the diagnostic card cannot find out the problem on my computer, what to do next?
- Answer: there are so many different types of computers with different daily updated motherboards designs on the market. No single motherboard diagnostic card can diagnosis all computers and find all the problems. This diagnostic card just like all others, but we always do our best works to make our diagnostic cards superior than any others and also to works on more computers than others.
- Thanks for your trusts and supports on Qiguan!